

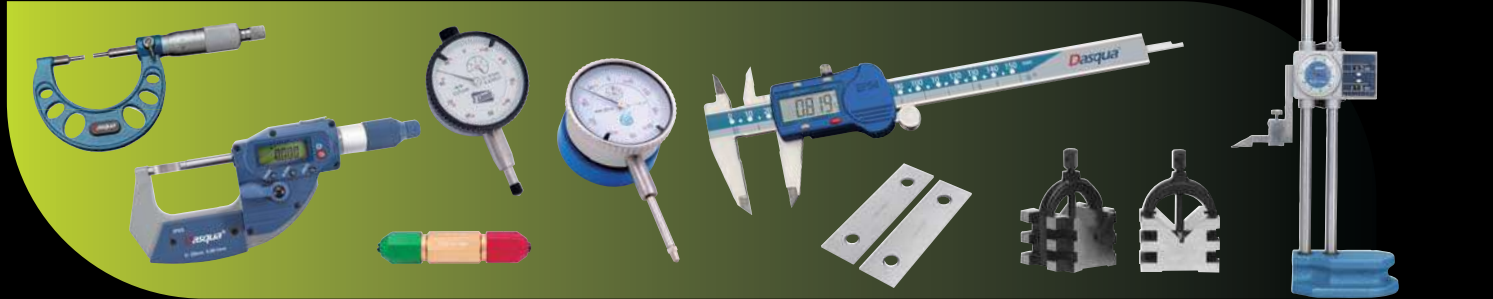

Vinculo

INDUSTRIAL TOOLS SUPPLY

PRECISION MEASURING TOOLS



CUTTING & CARBIDE TOOLS



MACHINE TOOL ACCESSORIES



SHOP SUPPLIES



CAT. No. 30N

Effective 2022

WORK LIGHTS & MAGNIFIERS

FLEXIBLE SHAFT WATERPROOF IP54 LED WORK LIGHT

- CREE XPG high performance LED light provides an excellent solution for heat sensitive environment.
- Small head (0.8" Diameter) with zoom ring for adjusting brightness
- IP54 dustproof and waterproof
- Strong magnetic base with 1.5" diameter grip can be handled as a flash light or stick on a metal surface.
- Battery Run Time: 8 hours high(200 LUMENS), 20 hours low(80 LUMENS)
- On/Off button
- 18" flexible shaft.
- Use 3xAA battery.

IP 54

OVERALL LENGTH: 24"
BRIGHTNESS: 200 LUMENS



8401-0439

Unit: mm

LAMP ON MAGNETIC BASE

- Powerful magnetic base with On/Off switch.
- Guaranteed power pull 130 lbs.
- Flexible arm for any position adjustment.
- 60 VA power rating.
- Power supply: 115V/ 60Hz/ 1 Phase.
- Uses regular screw-on bulb (not included).
- Base Dimension: 2-5/16" L x 2" W x 2" H

8401-0049



WORK LIGHT ON MAGNETIC BASE WITH FLEXIBLE ARM

8401-0050

MADE IN TAIWAN

- Powerful magnetic base with On/Off switch, holding power 180 lbs.
- Magnetic base dimension: 2-5/16 L x 2 W x 2" H
- Loc-line style flexible arm
- Use regular screw-on bulb(not included)
- Power Supply: 110V/1 Phase



8x LED LIGHT DESK TOP MAGNIFIER

- 8x powerful magnifier in diopters
- Flexible arm any desired position adjustable
- Diameter of Visible Area: 5"
- Adjustable LED light with 300 LUX brightness, 2.5Watt.
- Power Supply: 110V/1 phase
- Furnished with 60" cord.

8070-0001



BRIGHTNESS: 300 LUMENS

Replacement Bulb (8070-0004)

WATERPROOF LED WORKING LIGHTS-Small Head

- LED lights (1.1 Watt) provide an excellent solution for heat sensitive environment.
- Small head (1.2" Diameter) with high brightness
- 50,000 hours LED lifetime
- Arm Length: 21.50".
- Power Supply: 110V AC/ 1 phase.

BRIGHTNESS: 110 LUMENS



Bolt On
8401-0458

Bolt-On Mounting Plate:
2-3/8 x 2-3/8"

With Mag. Base
8401-0459

Magnetic Base: 2-3/8 x 2-3/8"
with 110 lbs power pull.

WATERPROOF LED WORKING LIGHTS

- LED lights provide an excellent solution for heat intensive environment.
- High Brightness with 330 Lumens
- Magnetic Base: 2 x 2" with 110 lbs power pull.
- 50,000 hours LED lifetime
- Arm Length: 20".
- Power Supply: 110V AC/ 1 phase.
- Bolt-On Mounting Plate: 2 x 2"

BRIGHTNESS: 330 LUMENS



Bolt on WORK LIGHT
8401-0448

Work Light on Mag. Base
8401-0449

22" LED WORKING LIGHT-Bolt On

- LED lights provide an excellent solution for heat intensive environment.
- 18" goose neck.
- Lasts 50 times longer than regular flashlights.
- 30 LED bulbs provides brighter and stronger natural light.
- Power Supply: 110V AC/ single phase.



8401-0443

BRIGHTNESS: 250 LUMENS

25" LED WORKING LIGHT -On Magnetic Base

BRIGHTNESS: 250 LUMENS

- 18.5" gooseneck.
- Magnetic Base: 2-1/2x2" with On/Off switch, 150 lbs power pull.
- LED lights provide an excellent solution for heat intensive environment.
- Lasts 50 times longer than regular flashlights.
- 30 LED bulbs provides brighter and stronger natural light.
- Power Supply: 110V AC/ single phase.



8401-0445

7W WATERPROOF LED WORK LIGHT

- LED lights (7 Watt) provide an excellent solution for heat sensitive environment.
- The head of light installed filterable ultraviolet ray high temperature resisting glass and heat insulation structure
- Light head diameter: 4-3/8".
- Universal movement.
- 50,000 hours LED lifetime.
- Flux: 700Lm.
- Color temperature: 6500 K
- Power Supply: 110V AC/ 1 phase.
- Switch On/Off.

**Bolt-On Mounting Plate:
2-3/8 x 2-3/8"**

**With Swivel Arm
Total 18" Length (8+9")
8401-0466**

BRIGHTNESS: 700 LUMENS



INDUSTRIAL GRADE LED LAMP MAGNIFIER

- Light source LED, 390 Lums brightness.
- Lens Size: 7.5x6.0".
- Lens frame: 12x9".
- Lens material: glass.
- 3 diopter lens provides 1.75x magnification.
- Swing arm with 32" reach.
- Max. 2-1/2" adjustable bench clamp.
- Power On/Off switch.
- Power Supply: 115V.



BRIGHTNESS: 390 LUMENS

8401-0045

5W WATERPROOF LED WORK LIGHTS

- LED lights (5 Watt) provide an excellent solution for heat sensitive environment.
- Lights head diameter: 2-3/8".
- Universal movement.
- 50,000 hours LED lifetime.
- Flux: 350Lm.
- Color temperature: 6500 K
- Power Supply: 110V AC/ 1 phase.
- Plug-in to turn on.



**Bolt-On Mounting Plate:
2-3/8 x 2-3/8"**

**Without Arm
Overall Height 8"
8401-0462**

**BRIGHTNESS:
350 LUMENS**

**With Swivel Arm
Total 18" Length (8+9")
8401-0463**

HALOGEN WORK LIGHT - WATERPROOF

- Totally enclosed lighting head provides well prevention for dust, coolant and lubricants.
- Efficient quartz halogen bulb (50W), great light output, soft illumination.
- Coil transformer built in base for directly connect to AC 110 V power .
- Furnished with 6 ft cord with plug.
- Full reach: 36"

**BRIGHTNESS:
370~600 LUMENS**

**Work Light
8401-0452**

CE
MADE IN
TAIWAN

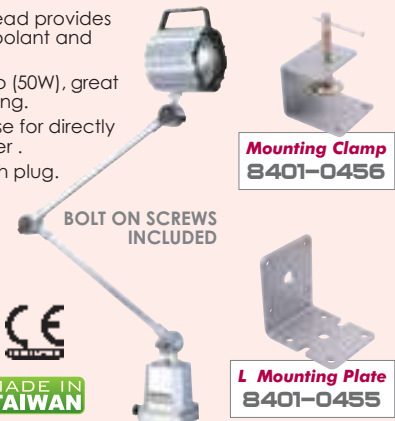

**Mounting Clamp
8401-0456**

**L Mounting Plate
8401-0455**

WORK LIGHTS

CONCENTRATE LED WORK LIGHTS-Bolt On

- Dust proof.
- Suitable for small CNC, engraving, sewing machine and heat sensitive environment.
- Flexible movement with folding arms.
- Built-in transformer
- Power consumption: 5.3W
- Input 110V AC, output 12V DC
- Sturdy rod-arm with special joint.

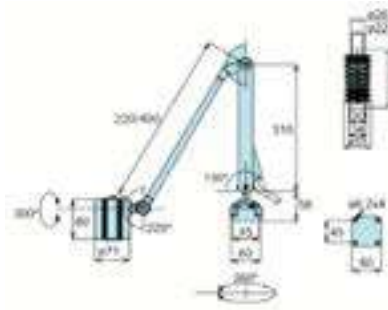

BRIGHTNESS: 330 LUMENS



MADE IN TAIWAN

Item #	Arm Length Lxl	Use Bulb	Weight Lbs.
8401-0481	220x310mm	6W	4.0
8401-0483	400x310mm	6W	4.5



IP65 WATERPROOF LED MACHINE WORK LIGHTS

- LED lights provide an excellent solution for heat sensitive environment.
- Color temperature: 6500 K.
- 50,000 hours LED lifetime.
- 4 slots (2 of each side) for bolt-on.
- Hardwire direct to your machine.

IP 65



24V VOLTAGE

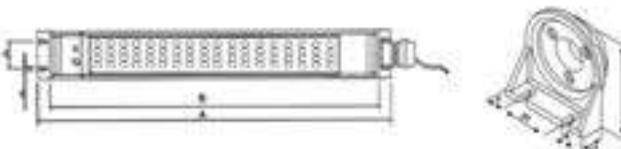

Item#	Input Voltage	Power	Length A/B(mm)	Flux Lm
8401-0470	24V	3.5 W	250/225	33
8401-0471	24V	7 W	360/335	660
8401-0472	24V	10.5 W	560/535	990
8401-0473	24V	14 W	760/735	1320

Pro-Series IP67 WATERPROOF TUBE LED MACHINE WORK LIGHTS

- IP67 rated water/collant proof.
- LED lights provide an excellent solution for heat sensitive environment.
- Color temperature: 6000~6500 K.
- Uniform distribution of light, excellent lighting effects and no glare.
- Diffusion plate gives high light transmittance and comfortable light for operators.
- 50,000 hours LED lifetime.
- Easy installation and low maintenance.
- High quality IP67 waterproof connector, aluminum PCB, Silicone rubber sealing ring and borosilicate glass tube (60mm Diameter).
- Ambient working temperature: -13°F~131°F(-25°C ~+55°C).
- Hardwire direct to your machine.



IP 67

While Supply Last!

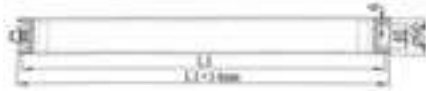

Item#	Power	Power Supply	(mm) Length L	(mm) Length L1	Flux Lm
8401-0491	13 W	110~270V/1 Phase	473	509	1300
8401-0492	17 W	24V AC/DC	528	564	1700
8401-0493	20 W	24V AC/DC	668	704	2000
8401-0494	24 W	24V AC/DC	773	809	2400

IP65 WATERPROOF HIGH FLUX LED MACHINE WORK LIGHTS

- Bright LED lights provide an excellent solution for heat sensitive environment.
- Color temperature: 6500 K.
- 50,000 hours LED lifetime.
- 4 slots (2 of each side) for bolt-on.
- Hardwire direct to your machine.



IP 65

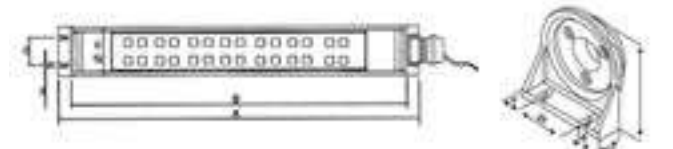

Item#	Input Voltage	Power	Length A/B(mm)	Flux Lm
8401-0477	24V	7.2 W	360/335	720
8401-0478	24V	11.2 W	560/535	1120
8401-0479*	110V	16.8 W	760/735	1680

*Plug Included

SAFETY SHIELD W/DISC MAGNETIC BASE

- Protects eyes from cutting chips
- Universal movement.
- Positively locks all with unique locking mechanism.
- Shield Dimension: 12 x 8"
- Super power disc magnetic base: 2.6" dia. x 0.4" depth.



4401-0517

SAFETY SHIELD WITH UNIVERSAL ARM-Clamp On

- Protects eyes from cutting chips.
- Shield Dimension: 12 x 9".
- Maximum Reach: 21".
- Universal arm can be locked at any positions with 3 knobs.
- Clamp on a shaft or a round bar with 1" diameter or less.

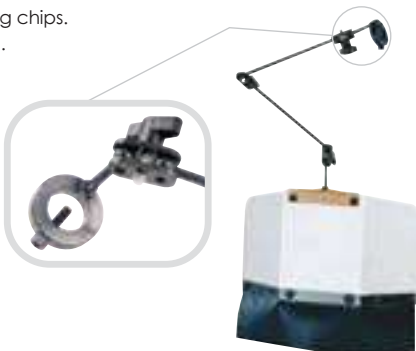

4401-0519

SAFETY SHIELD WITH MAGNETIC BASE



4401-0518

- Protects eyes from cutting chips
- Shield Dimension: 12 x 10"
- Magnetic base: 2.5 x 2 x 2".
- Permanent magnet with strong power pull 180 lbs..

MAGNETIC SAFETY SHIELD WITH ADJUSTABLE ARM



- Shield Size: 6 x 8"
- Reach: 12"
- Loc-Line style 3/4" hose, adjustable arm

4401-0516

MULTI FUNCTION MIST COOLANT SYSTEMS

- Air adjustment valve.
- Fluid control allows for right mixture for every job.
- Flexible tube (18") puts mist right where it is needed.
- For boring, milling, grinding or drilling operations.
- Fits on a standard mag base's vertical post, supplied with set screw to hold location.

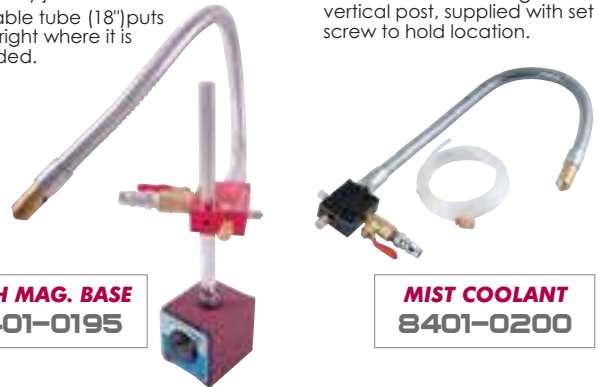

WITH MAG. BASE
8401-0195

MIST COOLANT
8401-0200

MIST COOLANT SPRAYER ON MAGNETIC BASE

- Air adjustment valve.
- Fluid control allows for right mixture for every job.
- Flexible Loc-Line style tube (17").
- For boring, milling, grinding or drilling operations.
- Magnetic base dimension: 2-5/16"L x 2"W x 2"H
- Magnetice Holding Power: 150 lbs



WITH MAG. BASE
8401-0196

COOLANT HOSE ON MAGNETIC BASE

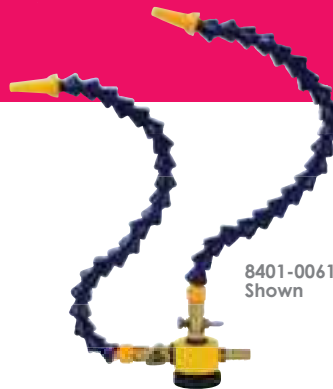

8401-0061
Shown

- Low profile magnetic base with 45 lbs power pull.
- Hose Length: 14" optimize coolant use and tool life.
- Shut off valve included.

Item #	Hose
8401-0060	Single
8401-0061	Dual

MAGNETIC BASE COOLANT HOSE ASSEMBLY

- 110 lbs magnetic pull.
- Two 1/4" dia. flexible coolant hoses.
- Either one can be shut off.
- On/ Off switchable magnetic base.



8401-0048

COOLANT SYSTEMS

SINGLE STEEL HOSE MAGNETIC BASE COOLANT ASSEMBLY

- Magnetic power pull: 150 lbs.
- Steel flexible hose with metal nozzle.
- Shut off valve.
- Hose length (from valve to tip of nozzle):12.5"
- On/Off switchable magnetic base.

MADE IN
TAIWAN

8401-0065



COOLANT TESTER-REFRACTOMETERS

- Accurately measures coolant concentration.
- Includes instructions.
- Optimize coolant use and tool life.
- Just a few drops needed for test.

Item#	Typical Coolant	Solution Measuring Range
8010-0018	Water Sol. or Synthetics	0~20%
8010-0019	Synthetics	0~15%
8010-0020	Water Soluble	0~30%



VERTEX 3 GALLON COOLANT PUMP KIT

- Portable and easy to use coolant device.
- Can be used on drilling, milling machines, small lathes and other equipment that needs cooling.
- Power supply: 110V/1 phase, 1/8 HP.
- Dimension: 15.5 L x 10.5 W x 13" H.
- Weight: 18 lbs

3 Gallon Kit
3012-8110



VERTEX Pro-Series 4.2 & 9-1/4 GALLON COOLANT PUMP KITS

- Portable and easy to use coolant device.
- Can be used on drilling, milling machines, small lathes and other equipment that needs cooling.
- Power supply: 110v/ 1 phase, 1/4 HP.
- Dimension: 19.7 L x 13.8 W x 7.9" H.
- Weight: 73 lbs

- **KIT INCLUDES:**
 - Coolant Pump
 - Coolant Tank
 - Connecting Cable (with plug for 1 ph)
 - Coolant Hose kit with Magnetic Base
 - Flexible Conveying Hose
 - Drain Hose
 - Tool Kits
 - ON/OFF switch (for 1 ph)

MADE IN
TAIWAN

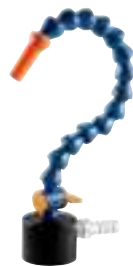

Item#	Coolant Pump (HP x Height)	Tank Size (L x W x H)	Volume of Coolant Tank	Connecting Cable	Coolant Hose Kit with Magnetic Base (O x L)	Flexible Conveying Hose (O x L)	Drain Hose (O x L)	Weight
3012-8115	1/8HP x 6"	15.75 x 9.85 x 7.25"	16 liters	7.87"	1/4 x 13"	3/8 x 6"	1 x 11.81"	23.8 lbs.
3012-8118	1/4HP x 7"	19.68 x 13.75 x 7.87"	35 liters	7.87"	3/8 x 14.17"	3/8 x 6"	1-1/4 x 15.74"	72.75 lbs.

VERTEX 1/8 HP UNDER WATER COOLANT PUMP

- This pump is high quality with anti-rust treatment, manufactured with high grade materials and inspected in five steps by a precision electronic device.

3012-8122

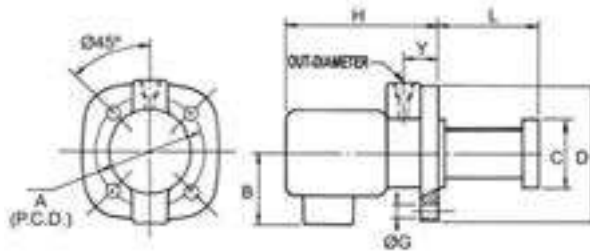
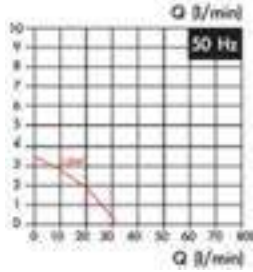

Power	Length (L)	Pumping Water 1mmin	Pumping Water 2mmin	A	B	C	D	G	H	Y	Out Diameter	Weight
1/8HP	150	27-28 L	25-26 L	128±0.2	105	Ø90	Ø150	Ø8	160	19	PT 3/8"	13 lbs.

VERTEX 1/4 HP UNDER WATER COOLANT PUMP

- This pump is high quality with anti-rust treatment, manufactured with high grade materials and inspected in five steps by a precision electronic device.

3012-8125

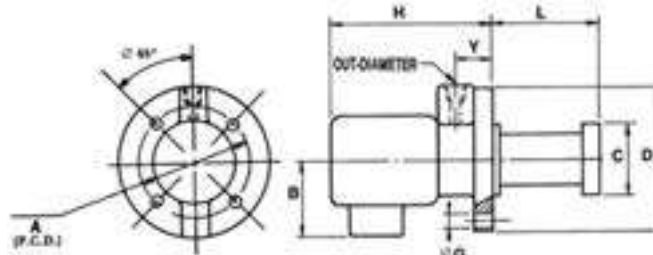
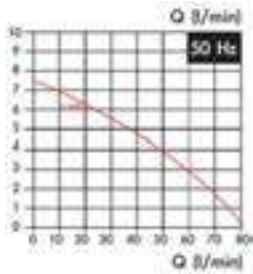

Power	Length (L)	Pumping Water 1mmin	Pumping Water 2mmin	A	B	C	D	G	H	Y	Out Diameter	Weight
1/4HP	200	74-76 L	71-72 L	158±0.2	125	Ø122	Ø180	Ø8	180	26	PT 1/2"	25 lbs.

VERTEX 1/8 HP SELF PRIMING COOLANT PUMP

- This pump is high quality with anti-rust treatment, manufactured with high grade materials and inspected in five steps by a precision electronic device.

3012-8128

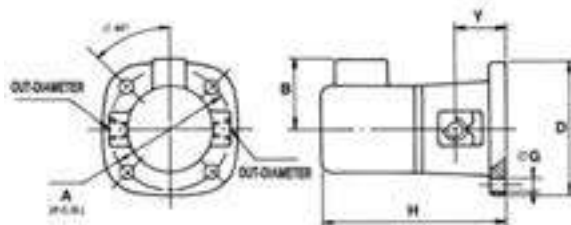
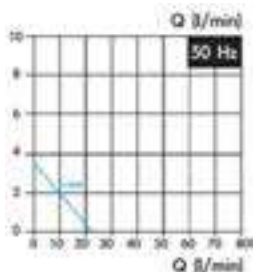

Power	Pumping Water 1mmin	Pumping Water 2mmin	A	B	D	G	H	Y	In Diameter	Out Diameter	Weight
1/8HP	26-28 L	24-25 L	140±0.2	105	165	Ø8	195	50±0.5	PT 3/8"	PT 3/8"	13 lbs.

ADJUSTABLE COOLANT HOSE SYSTEM

ADJUSTABLE COOLANT HOSE SYSTEM -Loc - Line style - Interchangeable

*Limited Supply

Buy A Pack and Save !

1/4" MALE NPT VALVE KIT
5pc/pack

8401-0209



1/2" MALE NPT VALVE KIT
5pc/pack

8401-0229*

1/4" I.D. COOLANT HOSE KIT, 7PC

8401-0251

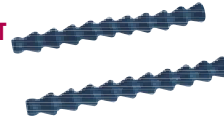

1/2" I.D. COOLANT HOSE KIT, 7PC

8401-0502



INCLUDES:
1/16, 1/8 & 1/4" Nozzle
and 1/8 & 1/4" NPT Connector
6" x 2pc Coolant Hose

INCLUDES:
1/4, 3/8 & 1/2" Nozzle
and 1/2 & 3/8" NPT Connector
6" x 2pc Coolant Hose

1/4" IN-LINE VALVE KIT
5pc/pack

8401-0210*



1/2" IN-LINE VALVE KIT
5pc/pack

8401-0230*

6" LENGTH, 1/4 COOLANT HOSE SET
2pc/pack

8401-0211

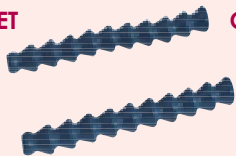

6" LENGTH, 1/2 COOLANT HOSE KIT
5pc/pack

8401-0231*

1/4" I.D. COOLANT HOSE KIT, 7PC

8401-0253



INCLUDES:
1/16, 1/8 & 1/4" Nozzle
1" Flare Nozzle and 3/8 SAE Flare Nut Adapter
6" x 2pc Coolant Hose

1/4" "Y" FITTING KIT
5pc/pack

8401-0202*



1/2" "Y" FITTING KIT
5pc/pack

8401-0222*

1/4" ELBOW FITTING KIT
5pc/pack

8401-0203*



1/2" ELBOW FITTING KIT
5pc/pack

8401-0223*

4PC 90° 1/4" NOZZLE KIT
(1/16, 1/8, 1/4" & Spray Bar)

8401-0208*



4PC 90° 1/2" NOZZLE KIT
(1/16, 1/8, 1/4" & Spray Bar)

8401-0228*

3PC (1/16, 1/8 & 1/4") ROUND NOZZLE SET

8401-0204



3PC (1/4, 3/8 & 1/2") ROUND NOZZLE SET

8401-0224*

NPT 1/4" CONNECTOR KIT
5pc/pack
For 1/4" hose

8401-0207



NPT 3/8" CONNECTOR KIT
5pc/pack
For 1/2" hose

8401-0227*

NPT 1/8" CONNECTOR KIT
5pc/pack
For 1/4" hose

8401-0206*



NPT 1/2" CONNECTOR KIT
5pc/pack
For 1/2" hose

8401-0226*

50FT BULK COOLANT HOSE COILS -Loc - Line style - Interchangeable

1/2 INCH
8401-0240*

*Limited Supply

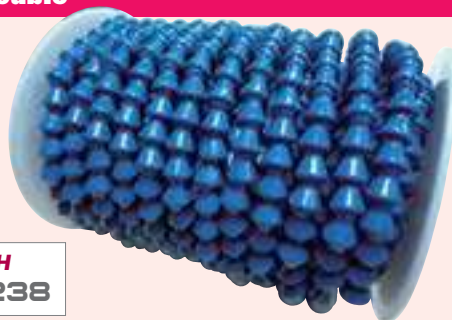

1/4 INCH
8401-0220

3/8 INCH
8401-0238

COOLANT HOSE WRENCHES

• Use for easy assembly of coolant hoses.

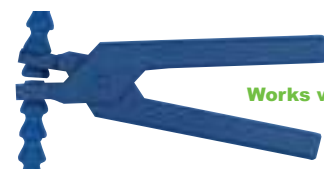

Works with Loc-Line!

HEAVY DUTY

1/4" Hose
8401-0504

1/2" Hose
8401-0506

5PC FLARING NOZZLE KITS

- Interchangeable with LoLine.
- For flexible hose system.

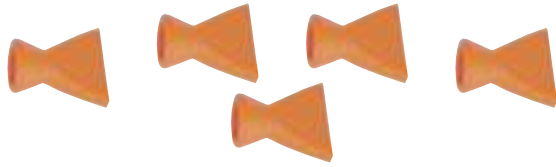

1" Flare, 1/4" I.D.
8401-0205

*Limited Supply

1-1/2" Flare, 1/2" I.D.
8401-0225*

AIR SANDER - Orbital Jitterbug Type

- Constant orbital stroke for fine finishing.
- Dynamic counter weight for low vibration sanding.
- Automatic throttle release lever with positive stop action.
- Pad Size: 3-2/3" x 6-1/2".
- Speed: 8,000 RPM
- Air Inlet: 1/4" NPT.
- Hose Size: 3/8".
- Air Consumption: 5 CFM.
- Air Pressure: 90 PSI.



7600-0118

Replacement Pad (Item #7600-0119)

Pistol Type AIR DUSTER BLOW GUNS -Heavy Duty



Limited Supply!

- Body made of Alumium Casting for long lasting durability.
- Max. Working Pressure: 180 psi
- Comfort trigger design
- Quick coupling connector included

Gun with 5/8" Tube
7600-0191

Gun with 4" Tube
7600-0192

1/8" ECONOMY MINI AIR DIE GRINDER

SPECIFICATIONS

Free Speed (RPM).....	54,000
Air Inlet (NPT).....	1/4"
Collet chuck.....	1/8"
Air pressure (PSI).....	.90
Length.....	5-1/4"
Weight.....	1/4 lbs



7600-0086

Pro-Series 1/8" MINI AIR DIE GRINDER

- Pen type is ideal for access to confined areas
- Operates at 54,000 RPM at 90 PSI
- Includes 1/8" collet, wrenches and quick connect coupler

MADE IN TAIWAN

7600-0088

SPECIFICATIONS

Free Speed (RPM).....	54,000
Air Inlet (NPT).....	1/4"
Collet chuck.....	1/8"
Air pressure (PSI).....	.90
Length.....	5-1/4"
Weight.....	1/4 lbs



SUPPLIED WITH WATER/OIL SEPERATOR

AIR BLOW GUN & SET

- **SET INCLUDES:**
- 1 - Blow gun with rubber tip
- 3 - Safety extension tubes
- 1 - Male tip

BLOW GUN ONLY
7600-0169

5 PC SET
7600-0170



360 DEG. PNEUMATIC HOSE FITTING & COUPLING

- Made of Alumium Alloy
- Swivel 360°
- Max. Working Pressure: 140 psi
- Thread: 1/4 NPT x 1/4 NPT (Male x Female)

Limited Supply!

8401-0249



5PC 1/4" QUICK - COUPLER SET

- **SET INCLUDES:**
- 1 - NPT female quick connector
- 1 - NPT female/male stud
- 3 - Male/male stud

7600-0171

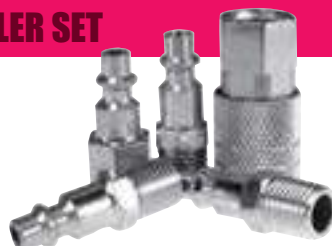

Z-Limit ERGONOMIC LOW NOISE 1/4" AIR DIE GRINDER KIT



- Rubber molded cushion grip
- Air regulator on top
- Safety throttle lever
- Rear exhaust with silencer
- 360 degree swivel air inlet
- Low noise 79 dB(A)
- Free Speed: 20,000 RPM
- Air Inlet: 1/4" NPT
- Hose Size: 3/8"
- Air Pressure: 90 PSI
- Air Consumption: 4 CFM
- Overall Length: 7-3/8"

Kit Includes:

- 1-Air Die Grinder
- 5-1/4" Shank Mounted Stone
- 5-1/8" Shank Mounted Stone
- 1-Fitted Blow Case

MADE IN TAIWAN

7609-0901

Limited Supply!



1/4" MINI AIR DIE GRINDER

- Light weight construction
- Ball bearing construction
- Variable speed throttle

SPECIFICATIONS	
Speed (RPM).....	22,000
Air Inlet (NPT).....	1/4"
Collet chuck.....	1/4"
Length.....	4"



7600-0902

1/4" ECONOMY AIR DIE GRINDER

7600-0089

SPECIFICATIONS	
Speed (RPM).....	22,000
Collet chuck.....	1/4"
Air inlet(NPT).....	1/4"
Hose size (ID).....	3/8"
Air Consumption.....	4 CFM
Air-pressure (PSI).....	90
Overall Length.....	7-3/8"



1/4" HEAVY DUTY AIR DIE GRINDER

- Heavy Duty.
- Built in Safety Lever to meet OSHA requirements.
- Variable speed throttle for positive speed control.
- Ball bearing construction for long tool life.
- Rear exhaust.

HHP PRO-SERIES

SPECIFICATIONS	
Speed (RPM).....	22,000
Collet chuck.....	1/4"
Air inlet(NPT).....	1/4"
Hose size (ID).....	3/8"
Air-pressure (PSI).....	90



7600-0911

ABRASIVE CUT-OFF WHEEL MANDRELS

CAUTION: Never exceed maximum RPM rating. Always use a guard and comply with ANSI B7.1.



2PC ARBOR SET
3900-6376

1/4 & 3/8"

Item#	Arbor	Shank
3900-6250	1/4"	1/4"
3900-6375	3/8"	1/4"

Z-Limit ERGONOMIC LOW NOISE 1/4" MINI AIR DIE GRINDER

- Rubber molded cushion rip
- Air regulator on top
- safety throttle lever
- Rear exhaust with silencer
- Free speed: 25,000 RPM
- Low noise 79 dB
- Air inlet: 1/4 NPT
- Hose size: 3/8"
- Air Pressure: 90 PSI
- 360° swivel air inlet.
- Air Consumption: 4 CFM
- Overall Length: 6-1/4"
- Weight: 1 lbs.

Limited Supply!

Z-Limit
ULTRA-SERIES

7609-0902



MADE IN TAIWAN

Z-Limit ERGONOMIC LOW NOISE 1/4" AIR DIE GRINDER

- Rubber molded cushion grip
- Air regulator on top
- Safety throttle lever
- Rear exhaust with silencer
- 360 degree swivel air inlet
- Low noise 79 dB(A)
- Free Speed: 20,000 RPM
- Air Inlet: 1/4" NPT
- Air Pressure: 90 PSI
- Air Consumption: 4 CFM
- Overall Length: 7-3/8"
- Hose Size: 3/8"
- Weight: 1.5 lbs

Z-Limit
ULTRA-SERIES

7609-0903



MADE IN TAIWAN

Z-Limit ERGONOMIC LOW NOISE 1/4" ANGLE AIR DIE GRINDER

- Rubber molded cushion grip
- Air regulator on top
- Safety throttle lever
- Rear exhaust with silencer
- 360 degree swivel air inlet
- Low noise 77 dB(A)
- Free Speed: 20,000 RPM
- Collet Size: 1/4"
- Air Inlet: 1/4" NPT
- Hose Size: 3/8"
- Air Pressure: 90 PSI
- Air Consumption: 4 CFM
- Overall Length: 6-11/16"
- Weight: 1.1 lbs

Z-Limit
ULTRA-SERIES

7609-0904



MADE IN TAIWAN

REPLACEMENT COLLETS

- Fits all air tools with same collet size

Item#	Chuck Size	Fits Air Tool
7600-1003	1/8"	1/8"
7600-1001	1/8"	1/4"



1/4" ECONOMY ANGLE AIR DIE GRINDER

- Collet size: 1/4".
- Air inlet: 1/4".
- I.D. air hose: 3/8".
- 90 PSI air pressure.
- 20,000 RPM speed.
- 4 CFM air consumption.
- Built in Safety Lever to meet OSHA requirements.

7600-0093



1/2" DRIVE AIR IMPACT WRENCH

- Bolt capacity.
- Maximum torque: 250ft/lbs.
- 90 PSI air pressure.
- 5 CFM air consumption.
- 7000 RPM speed.

7600-0942



3/8" AIR RATCHET WRENCH

- Maximum torque: 50ft/lbs.
- 150 RPM speed.
- Air inlet: 1/4".
- 90 PSI air pressure.
- 4 CFM air consumption.
- Overall length: 10".

Limited Supply!

3/8" DRIVE
7600-0931



1/4" ANGLE AIR DIE GRINDER

- Built in Safety Lever to meet OSHA requirements.
- Collet size: 1/4".
- Air inlet: 1/4".
- I.D. air hose: 3/8".
- 90 PSI air pressure.
- 20,000 RPM speed.
- 4 CFM air consumption.

HHIP
PRO-SERIES

7600-0092



MADE IN TAIWAN

Z-Limit 3/8" ERGONOMIC LOW NOISE AIR RATCHET WRENCH

- Rubber molded cushion rip
- Rear exhaust with silencer
- Low noise 79 dB
- Free speed: 150 RPM
- Maximum torque: 60 ft/lbs
- Air inlet: 1/4 NPT
- Air Pressure: 90 PSI
- Air Consumption: 4 CFM
- Overall Length: 10-3/8"
- Weight: 2.8 lbs.

Z-Limit
ULTRA-SERIES

3/8" DRIVE
7609-0931

Limited Supply!



MADE IN TAIWAN

Pro-Series 3/8" REVERSIBLE AIR DRILL

- Rubber molded cushion rip
- Rear exhaust with silencer
- Composite motor housing.
- Variable speed trigger
- Standard keyless chuck.
- Free speed: 2,000 RPM
- Chuck Size: 3/8"
- Spindle Thread: 3/8"-24
- Air Inlet: 1/4 NPT
- Hose Size (ID): 3/8"
- Air Pressure: 90 PSI
- Air Consumption: 4 CFM
- Overall Length: 7-5/8"
- Weight: 2.2 lbs.

Z-Limit
ULTRA-SERIES

Limited Supply!

7609-0095



MADE IN TAIWAN

HEAVY DUTY 3/8" REVERSIBLE ANGLE AIR DRILL

- 90° angle head.
- Rear exhaust, low noise
- Forward and reverse knob.
- Variable speed lever.
- Standard keyed chuck.
- Free speed: 1,200 RPM
- Chuck Size: 3/8"
- Spindle Thread: 3/8"-24
- Air Inlet: 1/4 NPT
- Hose Size (ID): 3/8"
- Air Pressure: 90 PSI
- Air Consumption: 4 CFM
- Overall Length: 8"
- Weight: 2.5 lbs.

Limited Supply!

7609-0098



MADE IN TAIWAN

PUSH TO CONNECT FITTINGS

PUSH TO CONNECT MALE TUBE FITTINGS

- Max. Air Pressure: 0-10 kgf/cm²
- Metal body, nickel plated
- Pre applied teflon thread sealant
- Temperature: -5~60 °C
- Push-in tube to connect

Limited Supply!



Item#	Tube OD	Pipe Thread	Overall Length (mm)
8401-0275	1/8	NPT 1/8	20
8401-0276	1/8	NPT 1/4	20
8401-0280	1/4	NPT 1/8	22
8401-0286	3/8	NPT 1/8	30
8401-0287	3/8	NPT 1/4	31
8401-0288	3/8	NPT 3/8	29

PUSH TO CONNECT MALE TUBE ELBOW FITTINGS

- Max. Air Pressure: 0-10 kgf/cm²
- Thermo plastic body, nickel plated metal thread side.
- Pre applied teflon thread sealant
- Temperature: -5~60 °C
- Push-in tube to connect

Limited Supply!



Item#	Tube OD	Pipe Thread	Length A (mm)	Length C (mm)
8401-0294	1/8	NPT 1/8	24.9	18
8401-0295	1/8	NPT 1/4	26.9	18
8401-0298	1/4	NPT 1/8	27.3	20
8401-0299	1/4	NPT 1/4	29.3	20
8401-0300	1/4	NPT 3/8	30.3	20

NPT SINTERED BRONZE EXHAUST MUFFLERS

- Max. Air Pressure: 0-10 kgf/cm²
- Metal body, nickel plated
- Temperature: -20~70°C
- Decibel Rating: 75.000



Item#	NPT Thread	Hex Size (mm)	Overall length
8401-0320	1/8	12	0.94"
8401-0321	1/4	16	1.23"
8401-0322	3/8	18	1.47"
8401-0323	1/2	24	1.72"

NPT SINTERED BRONZE EXHAUST MUFFLERS

- Exhaust & Intake mufflers
- Metal body, nickel plated Breather Vent
- Temperature: -20~70°C



Item#	NPT Thread	Hex Size (mm)	Overall length
8401-0328	1/8	12	0.45"
8401-0329	1/4	16	0.55"

4 WAY HAND OPERATED VALVES-ROTARY DISC TYPE

- Body made of Aluminum Alloy
- Max. Working Pressure: 150 psi
- Number of Positions: 3
- Actuator Type: Lever/Detent



Item#	Inlet Size (Inch)	CV Rating
8401-0255	3/8	1.83
8401-0256	1/2	1.83

5 WAY HAND OPERATED VALVES-LEVER TYPE

- Body made of Aluminum Alloy
- Max. Working Pressure: 120 psi
- Number of Positions: 2
- Actuator Type: Lever/Detent

Limited Supply!



Item#	Inlet Size (Inch)	Outlet Size (Inch)	CV Rating
8401-0260	1/4 NPT	1/4 (2) & 1/8 (2)	0.67

3 WAY MANUAL MECHANICAL VALVE

- Body made of Aluminum Alloy
- Max. Air Working Pressure: 250 psi
- Number of Positions: 2

Limited Supply!



Item#	Inlet Size (Inch)	Outlet Size (Inch)	CV Rating
8401-0263	1/4 NPT	1/4 NPT	0.89

4&6 PORT STRAIGHT CONNECTION MANIFOLDS

- Body made of Aluminum Alloy
- Max. Working Pressure: 120 psi
- Number of Positions: 2
- Inlet Size: 1/4 NPT
- Outlet Size: 1/4 NPT

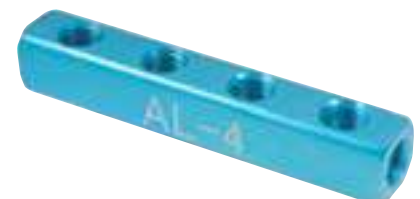

Item#	Port	Width x Height	OAL
8401-0310	4	0.85 x 0.85"	5"
8401-0312	6	0.85 x 0.85"	7"

1 PC FILTER/REGULATOR UNIT WITH DRAIN



- Max. Working Pressure: 150 psi
- Max. temperature: 70°C
- Manual drain type.
- Bowl Capacity: 25 ml (included)
- Pressure Gauge Included, 1/8 NPT mounting
- Dimensions: 2.5 x 3 x 7.4"

Heavy Duty!

Limited Supply!

Item#	Inlet Size (Inch)	Outlet Size (Inch)
7600-1755	1/8 NPT	1/8 NPT
7600-1756	1/4 NPT	1/4 NPT

1 PC FILTER/REGULATOR UNIT WITH DRAIN



- Max. Working Pressure: 150 psi
- Max. temperature: 70°C
- Manual drain type.
- Bowl Capacity: 25 ml (included)
- Pressure Gauge Included, 1/8 NPT mounting
- Dimensions: 2 x 3 x 6"

Limited Supply!

Clear Bowl

Item#	Inlet Size (Inch)	Outlet Size (Inch)
7600-1760	1/8 NPT	1/8 NPT
7600-1761	1/4 NPT	1/4 NPT

3PC FILTER/REGULATOR/LUBRICATOR UNITS

- Max. Working Pressure: 150 psi
- Max. temperature: 70°C
- Manual drain type.
- Dimensions: 5.4 x 3 x 5.2"
- Bowl Capacity: 15 ml & 25 ml (included)
- Pressure Gauge Included, 1/8 NPT mounting

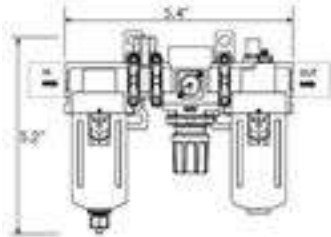

Limited Supply!



Item#	Inlet Size (Inch)	Outlet Size (Inch)
7600-1770	1/8 NPT	1/8 NPT
7600-1771	1/4 NPT	1/4 NPT

2PC FILTER/REGULATOR/LUBRICATOR UNIT

- Max. Working Pressure: 150 psi
- Max. temperature: 70°C
- Manual drain type.
- Bowl Capacity: 25 ml (included)
- Pressure Gauge Included, 1/8 NPT mounts.
- Dimensions: 3.5 x 3 x 6.2"



Limited Supply!

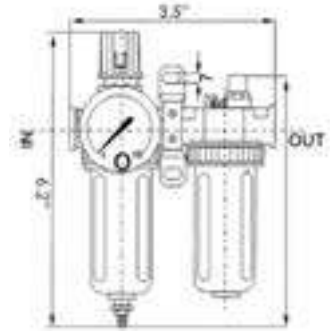

Item#	Inlet Size (Inch)	Outlet Size (Inch)
7600-1765	1/8 NPT	1/8 NPT

ELECTRICAL (P.V.C.) TAPE



Limited Supply!

**3/4" x 60 FT.
8070-0015**

PRICED AND SOLD BY 10PC/PACK

TEFLON TAPE



**1/2" x 520 FT.
8070-0003**

PRICED AND SOLD BY 10PC/PACK

SHOP APRON

- 14 oz. heavy denim apron
- 1 side pocket & 1 two part big pocket



**28" Wide x 36" Long
8070-7004**

Markal PRO-LINE FINE TIP MARKERS

For Precision Marking

- Fine tip sizes (2mm) for precise, permanent paint marking.
- High-strength, lightweight barrel designed for industrial-grade use.
- Ideal for metal, also suitable for wood, glass, plastic, rubber and more.
- Xylene-Free for less odor.
- Self-storing cap with clip protects tip for longer life and stores easily in pocket.



Color	Item#	Color	Item#
White	8030-9671	Blue	8030-9675
Yellow	8030-9672	Green	8030-9676
Black	8030-9673	Orange	8030-9677
Red	8030-9674		

ITW DYKEM BRITE-MARK MARKERS

- Makes permanent marks on metal, rubber, plastic, glass, concrete, leather, stone, wood, vinyl and more
- Valve action mechanism prevents paint in barrel from drying when cap is left off
- Heavy-duty aluminum barrel retains its shape
- Felt tips are replaceable to assure complete use of paint in each marker
- Drying time 25-35 seconds



For Marking On Any Surface! REGULAR (Medium) LINE

Item#	Color	Case Qty
8030-8401	Blue	48
8030-8402	Black	48
8030-8403	White	48
8030-8404	Yellow	48
8030-8405	Orange	48
8030-8406	Red	48
8030-8407	Green	48
8030-8408	Silver	48
8030-8409	Gold	48

ITW DYKEM HI-SPOT BLUE

Hi-Spot is an intensely blue, soft uniform paste that spreads easily and evenly to show high spots on bearings. A thin coating may be left on the surface day in and day out, and will not dry. The film remains pliable and transferable and in condition for months.

- Non-drying
- Non-hardening
- Transfers from one surface to another

.55 OZ. TUBE
8030-8355



WELDER'S ANGLE VISES

- Brass lead screw & nut.
- One piece structure.
- 90° angle

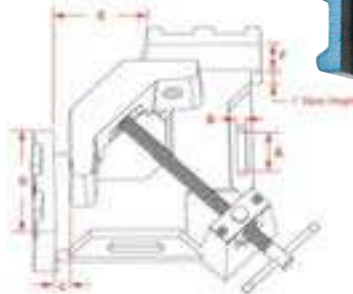

Item#	Jaw Length D	Jaw Height F	Jaw Opening C	A	B	E
3900-1724*	4"	1-3/8	2-3/8	1.77"	0.51"	2.95"
3900-1725	5"	2-3/8	4	2.56"	0.59"	3.15"

*Limited Supply

7 WAY MIG WELDING PLIER

- Small serrated hole for mig tips.
- Flat surfaces for light hammering.
- Wire cutter for trimming mig wire.
- Spring loaded handle with heavy insulated grip for comfort.
- Needle nose grip wire for pulling
- Large serrated hole for nozzles.



8080-0026

ALNICO POT MAGNETS

- Tapped hole in the center
- Made in Taiwan
- Magnetic circuit design for strong holding



Limited Supply!

Item #	Size(mm) Dia. x H	Hold Power	Tapped Hole	Wt. Lbs
4401-0820	30 x 25	40 lbs.	M6 x 1.00	0.26
4401-0822	40 x 30	66 lbs.	M8 x 1.25	0.57
4401-0824	50 x 40	110 lbs.	M8 x 1.25	1.20

MAGNET HOLDER

- Tapped hole in the center
- Made in Taiwan
- Strong holding power
- Useful



Limited Supply!

Item #	Size(mm) L x W x H	Hold Power	Tapped Hole	Wt. Lbs
4401-0816	26 x 60 x 25	44 lbs.	M6 x 1.0	0.70

HEAVY DUTY DEMAGNETIZER

- Demagnetizes tools such as dies, cutters and punches.
- Operates on 115V AC with on/off switch, 80 W.
- Table Size: 7.14" W x 5.00" L x 4.00" H

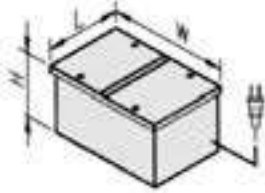

3401-0602



Pro-Series HEAVY DUTY DEMAGNETIZER

- Demagnetizes general parts, tools such as dies, cutters and punches.
- Operates on 115V AC , I Phase, 2A Current with on/off switch.
- **Automatic Temperature Protection: Power cuts off when reaches certain setting point. It will restart once it cools down (cycle time 10-20min).**
- Table Size: 7.1" W x 5.0" L x 3.5" H
- New Weight: 9 lbs.



MADE IN
TAIWAN



3401-0601

17 PC POWER PUNCH KIT

- Complete with 7 sets of punches and dies.
- Common sizes: 3/32", 1/8", 5/32", 3/16", 7/32", 1/4", 9/32".
- Punches and dies hardened to HRC 50-52.
- Pierces up to 16-gage metals. (steel, aluminum, brass, copper, plastic, etc.)
- Curved handles for a natural, balanced grip.
- Supplied with plastic carry case.

7070-0016



HEAVY DUTY TAPE MEASURE

- Made of heavy duty sheet metal steel.
- One inch wide blade.
- Hold up to 8' no break.
- Shows fraction by 8ths.
- Durable rubber outfit for easy grip



FRACTION SCALE

1" x 25 FT.
7020-0025

Dasqua® DIGITAL METRIC LASER TAPE MEASURES



- Measuring Accuracy: $\pm 3\text{mm}$
- Laser Class: 2
- Laser Type: 620-690nm, <1mW
- Operating Temperature: 0-40°C
- Storage Temperature: -20-70°C
- Display Type: OLED
- Multi-line Display: 2 lines
- Display Color: white on black
- Battery Life: 2000 measurements
- Battery Type: 3.7V Li-ion
- Laser Auto Off: After 30 seconds
- Power Auto Off: After 90 seconds
- 80.4mm x 46.4mm (with buckle)
- Tape width 2.5cm
- USB charging capability

- 3 in 1: tape measure, laser measure, digital display of tape
- 2 in 1: tape measure, laser measure

Item#	Measuring Range	Accuracy	Type
1804-1080	0.05-30m/5m	$\pm 3\text{mm}$	3in1
1804-1055	0.05-30m/5m	$\pm 3\text{mm}$	2in1

STAMPS & PUNCH SETS

STEEL STAMP COMBO SETS

- Hardened to RC 59-61 at tip and tempered to RC 40 Rockwell at striking end.
- Made from carbon steel.
- Character style designed to give sharp clear impressions.
- Packed in durable box.
- Easy selection and storage.



SET INCLUDES:

Numbers (0-9), Letters (A-Z)

Item#	Size of Impression
8016-0002	1/8"
8016-0003	3/16"
8016-0004	1/4"
8016-0005	3/8"

OPTICAL PUNCH SET

- This Optical Punch Set is indispensable when doing critical layout work. Just look down the magnifying lens and align the cross hairs with the mark on your workpiece. Replace the magnifier with the supplied punch and give it a tap.
- Punch set Includes 3 components a bull's eye and cross hair lens, a 120 degree made of tempered steel, a precisely manufactured of aluminum main body and a fitted case..



8600-4120

**Lens Magnifier Power: 9x
Punch Size: 3/8"
Pin Length: 1.85"**

OPTICAL PUNCH SET & 4PC CENTER DRILL SET COMBO KIT

- This Optical Punch Set is indispensable when doing critical layout work. Just look down the magnifying lens and align the cross hairs with the mark on your workpiece. Replace the magnifier with the supplied punch and give it a tap.
- Punch set Includes 3 components a bull's eye and cross hair lens, a 120 degree made of tempered steel, a precisely manufactured of aluminum main body and a fitted case.
- 4pc HSS combined drill & countersink set: #1-#4
- Made of high speed steel and ground.
- Plain style.
- Use for centering work ends, where the workpiece is to be revolved on machine centers, 60° countersink angle fits at standard centers.



**Lens Magnifier Power: 9x
Punch Size: 3/8"
Pin Length: 1.85"**

NEW

Size	Body Dia	(Inch) Drill Dia	OAL
1	1/8	3/64	1-1/4
2	3/16	5/64	1-7/8
3	1/4	7/64	2
4	5/16	1/8	1-1/8

**Combo Kit
8600-4122**

Pro-Series 36PC NUMBER/LETTER STEEL STAMP KITS

- Sand blasted surface finish.
- Kit consists of A-Z letters & 0-9 numbers.
- Made of high grade tool steel, each character is hardened and tempered to 60-62 HRC.
- Heavy duty plastic case.



Item#	Size of Impression
8016-0012	1/8"
8016-0013	3/16"
8016-0014	1/4"
8016-0015	3/8"

MACHINISTS' BENCH BLOCK

- Made from steel-hardened and ground
- A handy tool for holding work when driving pins, drilling, etc.
- The knurled side provides a good gripping surface
- V-groove across the face accommodates round and odd shaped stock
- Holes from 1/8 to 5/8 (3-16mm) diameter

3600-0042

3" Dia. x 1-1/2" H



DISC CUTTER SETS

- Punches are made of tool steel, case-hardened.
- The top and bottom plates are made of durable shock-resistant tool steel through hardened for long-wear.
- Round disc cutters let you cut perfectly round discs in up to 1mm (18 gauge) thick metal sheets.
- Slide metal between the plates and, with a mallet or heavy hammer of your choice, hit once for best results.



**INCH, 7PC Set
8606-4127**

7PC INCLUDES DISC SIZES: 1/4, 5/16, 3/8, 7/16, 1/2, 9/16 & 5/8"

**Block Size: 2.44x2.42x0.98"
Punches Length: 1.50"**



**METRIC, 14PC Set
8606-4130**

14PC INCLUDES DISC SIZES: 3.0, 4.5, 5.0, 6.0, 7.0, 7.5, 8.0, 8.5, 10.0, 11.0, 12.0, 13.0, 14.0 & 16.0mm

**Block Size: 4.20x1.93x0.93"
Punches Length: 1.55"**

8PC DRIVE PIN PUNCH SET

- Manufactured from fine tool steel hardened and tempered.
- Knurled body.
- Complete with vinyl pouch.
- Overall length: 4"

SET INCLUDES:

1/16, 3/32, 1/8, 5/32, 3/16, 7/32, 1/4 & 5/16"

8PC Set
8606-4106



8PC BRASS DRIVE PIN PUNCH SET

- Used in spark-free environments.
- Made from brass hexagonal stock.
- Punch section centerless ground.
- Supplied in plastic pouch.
- 3-1/2" overall length.
- Punch tip diameters are oversized approximately 0.005" (0.127mm).
- Set Includes: 1/16(1.6mm), 3/32(2.4mm), 1/8(3.2mm), 5/32(4.0mm), 3/16(4.8mm), 7/32(5.5mm), 1/4(6.4mm) & 5/16"(8.0mm)



8PC Set
8600-4110

8PC DRIVE PIN PUNCH SETS

- Tool steel heat treated, ground and polished.
- Knurled body.
- Complete with vinyl pouch.
- Overall length: 4"

8 PC SET INCLUDES:

1/16~1/4" by 32nds & 5/16"

8PC Set
8600-4107

8PC Set
8600-4106



8PC BRASS DRIVE PIN PUNCH SET

- Used in spark-free environments.
- Punch section centerless ground.
- Solid brass.
- Hexagonal body
- 4" length.
- Supplied in fitted case.

8PC Set
8600-4108



13PC COMBINATION DRIVE PIN PUNCH SET

- Tool steel heat treated, ground and polished.
- Knurled body.
- Complete with vinyl pouch.

SET INCLUDES:

8 pc. 4" length 1/16~5/16" and 5 pc. 8" length 1/8, 3/16, 1/4, 5/16 & 3/8" in vinyl pouch.

13PC Set
8606-4113



NEW

METAL SCRIBER

- Tempered and heat treated steel all over body, handle, and sharp tips.
- Long length handy for hard to reach holes.
- Knurled body for tight grip.

OAL: 9.50"

7600-4302



SCRIBER WITH CLIP

- For marking or engraving on hard metal, glass, plastic, ceramic, jewelry, etc.
- Sharp tungsten steel tip.
- Convenient pocket clip and covered cap.
- Knurled body grip.

7600-0044

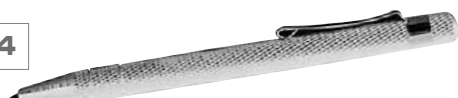

5PC EXTRA-LONG DRIVE PIN PUNCH SETS

- Black nitrate finish.
- Alloy steel hardened on both ends.
- Finger grip knurled body.
- Pin length: 3-1/2".
- Overall length: 8".
- Complete with vinyl pouch.

5 PC SET INCLUDES:

1/8, 3/16, 1/4, 5/16 & 3/8"

5PC Set
8600-4103

5PC Set
8600-4104



5" AUTO CENTER PUNCH

- No hammer required.
- Double spring loaded barrel.
- Special hardened alloy steel tip for instant marking.
- Knurled body.



8070-0482

TRANSFER SCREWS & DAPPING BLOCKS

25PC TRANSFER SCREW COMBO SETS

- Convenient & economic combination of four sizes often used together.
- More accurate than transfer punches. The fastest and most precise method of transferring threaded holes to mating parts. Great for tool and die work and in lay outs.
- Solid handle.
- Plastic storage case.



3601-0511 Shown

SET INCLUDES:

Handle & 24 Screws(6pc each size)



3601-0513 Shown

Item#	Set Thread
3601-0511	1/4-20, 5/16-18, 3/8-16, 7/16-14
3601-0513	1/2-13, 5/8-11, 3/4-10, 9/16-12
3601-0515	10-24, 8-32, 6-32, 4-40
3601-0517	M3x0.5, M4x0.7, M5x0.8, M6x1.0
3601-0519	M6x1.0, M8x1.25, M10x1.50, M12x1.75
3601-0521	M14x2.00, M16x2.00, M20x2.50, M24x3.00

7 PC TRANSFER SCREW SETS

- More accurate than transfer punches. The fastest and most precise method of transferring threaded holes to mating parts. Great for tool and die work and in lay outs.

SET INCLUDES: Handle & 6 Screws



Inch

Item#	Thread
3601-0004	4-40
3601-0006	6-32
3601-0008	8-32
3601-0010	10-24
3601-0011	10-32
3601-0012	12-24
3601-0250	1/4"-20
3601-0312	5/16-18
3601-0375	3/8"-16
3601-0376	3/8"-24
3601-0438	7/16"-14
3601-0500	1/2"-13
3601-0501	1/2"-20

MM

Item#	Thread
3601-1003	M3x0.5
3601-1004	M4x0.7
3601-1005	M5x0.8
3601-1006	M6x1.00
3601-1008	M8x1.25
3601-1010	M10x1.50
3601-1012	M12x1.75

40PC DAPPING DIE BLOCK & PUNCH SET

- Ideal for multi purpose formings.
- Made of hardened steel.
- Steel Dapping Block 2.5x2.5x2.5"(20 Depressions: 2.0, 3.2, 4.8, 6.4, 7.9, 9.5, 11.1, 12.7, 14.3, 15.9, 17.5, 19.1, 20.6, 22.2, 25.4, 27.0, 28.6, 31.8, 34.9, 44.5 & 50.8mm)
- Steel Flat Dapping Block: 5"x2.5"x1"(27 Depressions: 1.5, 2.0, 2.4, 2.8, 3.2, 3.6, 4.4, 4.8, 5.6, 6.4, 7.1, 7.9, 8.7, 9.5, 10.7, 11.1, 12.7, 14.3, 15.5, 15.9, 17.1, 17.5, 19.1, 20.6, 22.2, 23.8 & 25.4mm)
- Steel Forming Block: Half Round (18 Grooves 4-22mm).
- Forming block (60 x 60 x 50 mm): Constructed of hardened steel. It is with half-round, flat and right-angle grooves. It has different shaped grooves on all sides for shaping metals.
- 36pc Dapping Punches(3.5" Long): 3.5, 4.0, 4.5, 5.0, 5.5, 6.0, 6.5, 7.0, 7.5, 8.0, 8.5, 9.0, 9.5, 10.0, 10.5, 11.0, 11.5, 12.0, 12.5, 13.0, 13.5, 14.0, 14.7, 15.4, 16.2, 17.0, 17.8, 18.6, 19.4, 20.2, 21.0, 21.8, 22.6, 23.4, 24.2 & 25.0mm
- Wooden stand with index included.

SET INCLUDES:

- 1pc Dapping Block,
- 1pc Flat Dapping Block
- 1pc Steel Half Round Forming Block
- 1pc Flat&Right Angle Forming Block
- 36pc Punches



40PC Set
8606-3409

DAPPING DIE BLOCKS - Steel & Brass

- 2x2" block has 18 half-sphere depressions from 4 - 40 mm in diameter.
- 3x3" block has 9 half-sphere depressions from 22 - 62.5 mm in diameter.
- Ideal for doming soft metals with the use of dapping punches or arbor presses and making beads and shaping metals.



Steel
2x2x2" Shown

18 Sizes: 4,5,6,7,8,9,10,11,12,13,14, 16,18,20,25,30,35,40mm

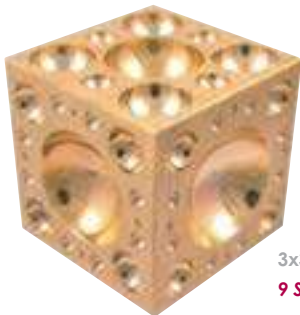

Brass
3x3x3" Shown

9 Sizes: 22,25,28,32,38,45,50,60 & 62.5mm

Block Size	Dapping Size	Steel Item#	Brass Item#
2" x 2"	4,5,6,7,8,9,10,11,12, 13,14,16,18,20,25,30, 35,40mm	8606-3400	8606-3410
3" x 3"	22,25,28,32,38,45, 50,60 & 62.5mm	8606-3402	8606-3412

TRANSFER PUNCH SETS

- Undersize .0025" .
- Heat treated tempered tool steel for longer life.
- Black oxide finish.
- Used for transferring of threaded, drilled and tapped holes.

28 PC SET
Range: 3/32-1/2" x 64ths
8600-0041



33 PC SET
Range: 1/2-1" x 64ths
8600-0411



Item#	No. of Pieces	Range
8600-0041	28	3/32-1/2" x 64ths & 17/32"
8600-0411	33	1/2-1" x 64ths
8600-0043	25	1-33mm x 0.5mm
8600-0044	26	A-Z
8600-0045	60	#1-60



REPLACEMENT RACKS FOR TRANSFER PUNCH SETS

- **Rack only.**
- Metal rack with sizes marked.



28PC Rack Shown

Item#	Description
8600-0041R	28PC Rack: 3/32-1/2" x 16ths
8600-0411R	33PC Rack: 1/2-1" x 64ths

24PC DAPPING DIE BLOCK & PUNCH SET

- Ideal for making beads and shaping metals.
- Dapping block(2x2") has 18 half-sphere depressions from 2.3 - 25 mm in diameter.
- 24pc Dapping Punches(3.5" long): 2.3, 3.5, 4.3, 5.1, 5.9, 6.7, 7.5, 8.3, 9.1, 9.9, 10.7, 11.5, 12.3, 13.0, 13.8, 14.6, 15.4, 16.2, 17.0, 18.6, 20.2, 21.8, 23.4 & 25.0mm.
- Hardned tool steel.
- Ideal for foming soft metals with the use of dapping punches or arbor presses.

SET INCLUDES:
Dapping Block, 24pc Punches
& Wood Stand with Index.

Metric, 24PC Set
8606-3406



61PC TRANSFER PUNCH COMBO SET

- Used for transferring threaded, drilled and tapped holes.
- Undersize .0025" .
- Heat treated tempered tool steel for longer life.
- Black oxide finish.
- 28pc Set Range: 3/32~1/2" by 64ths & 17/32"
- 33pc Set Range: 1/2-1" by 64ths

28PC & 33PC COMBO SET

Range: 3/32~1"
8600-0050



BUY COMBO SET & SAVE!

108 PC BLIND HOLE SPOTTER SET

- Fast, easy way to locate opposite centers. When holes do not extend through material(such as holes for dowel pins, perforating punches, etc.) Blind-hole spotters get the job done simply. Correct size spotter can be used in threaded, drilled or reamed holes.



8016-0108



INCLUDES:
1/8 to 21/32" by 32nds, 6pc each

HAMMERS & COUNTERS

Pro-Series PU-DEAD BLOW HAMMERS

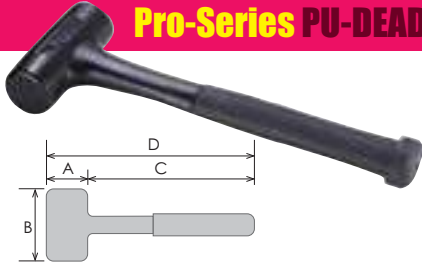

MADE IN TAIWAN

- Advanced Polyurethane (PU) material will not mar surfaces or absorb liquids.
- Basic: Steel structure and include steel shot.
- Absorbs shock from impact reduces rebound and maximizes force due to steel shot filled canisters.
- Grip is synthetic rubber improving grip and comfort.

Item#	Size OZ	A	(mm) B	C	D
7080-0331	18	38	100	249	287
7080-0333	24	46	100	260	306
7080-0336	33	50	110	290	340
7080-0339	49	60	130	308	368

DEAD BLOW HAMMERS

- Shot loaded interior produces a powerful driving force.
- Tough, durable polypropylene casting.
- Resistant to industrial chemicals.
- Non-marring, non-sparking.



Item#	Size (lbs.)	Head Dia.(In)	Overall Length
7080-0291	1	1-3/4	12"
7080-0292	2	2	13-1/2"
7080-0293	3	2-1/2	14-1/2"
7080-0294	4	3-1/2	15"

BRASS HAMMERS FIBERGLASS HANDLE

- Industrial grade.
- Non-Marring, non-sparking.
- Polished high purity brass heads.



Item#	Size (lbs.)	Head Dia.(In)	Overall Length
7080-0036	1	1-1/8	11-1/2"
7080-0037	1-1/2	1-1/4	12-1/2"

RATCHET DIGITAL READOUT COUNTER

- Reset knob.
- Base: 2-1/8 x 1-3/4".
- 5 digits.
- Height: 1-1/4".



3900-0203

HANDHELD 4 DIGIT COUNTER

- Chrome plated
- 2" Height x 1-3/4" Width
- Finger ring for easy handling
- Supplied with steel base

3900-0204



NYLON FACE DEAD BLOW HAMMERS

- Shot loaded interior produces a powerful driving force.
- Nylon material strike faces.
- Resistant to industrial chemicals.
- Non-marring, non-sparking.

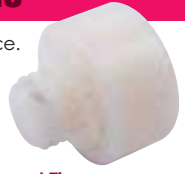

Replacement Tip

Item#	For Size (OZ.)
7080-0310	12
7080-0311	20

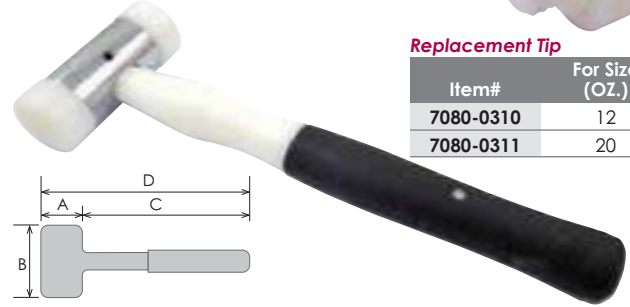

Item#	Size (OZ.)	Head Dia. A	Head Length B	Overall Length D
7080-0300	12	1.0"	4"	11"
7080-0301	20	1.5"	4"	11.5"

DEAD BLOW HAMMERS - UPE PLASTIC

- Shot loaded interior produces a powerful driving force.
- UPE material strike faces.
- Resistant to industrial chemicals.
- Non-marring, non-sparking.



Replacement Tip

Item#	Size (OZ.)	Head Dia.(In)	Overall Length	Item#	For Size (OZ.)
7080-0302	16	1.2	11"	7080-0312	16
7080-0305	29	1.6	11.8"	7080-0315	29
7080-0308*	46	2.2	12.6"	7080-0318*	46

* Limited Supply

FIBERGLASS HANDLE BALL PEIN HAMMERS

Limited Supply!

Item#	Size (oz.)
7080-0202	12
7080-0022	32
7080-0231	48



- Drop forged and fully polished.
- Hardened on striking face.
- Industrial grade.

HEAVY DUTY TIE DOWN

- Heavy duty ratchet tie down.
- Quick automatic release.
- Safe and secure type.

Limited Supply!



Item#	Size (W x L)	Capacity (lbs)
8010-0002	1" x 15 ft.	1,000
8010-0001	2" x 27 ft.	6,500

WINDOW DIRECT READOUT TORQUE WRENCH

- Meets or exceeds ISO 6789, US Fed. GGG-W-686D & ANSI B107.14M.
- Chrome-vanadium ratchet gear (32 teeth) and fully heat treated handle.
- Patented unique pull-push system, micro-click & reversible.
- Dimension: Width of Head 1.4", Depth of Head 1.23", OAL 19.5"
- Release accuracy $\pm 3\%$ • Push locking.
- Window scale design for easy reading.
- With fitted case.

1/2" DRIVE

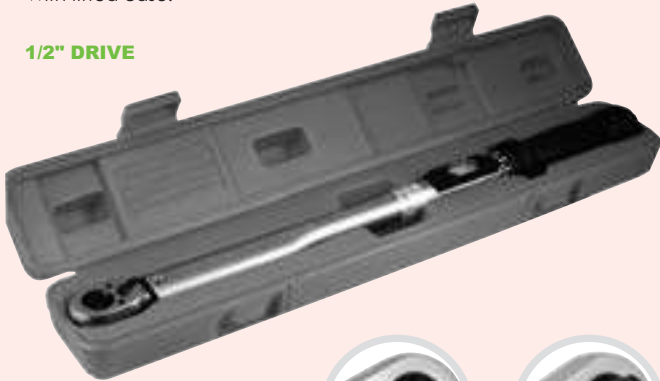

Item#	Drive	Torque Range	Graduation
7020-0151	1/2"	120~150 ft/lbs (30-210Nm)	10ft/lbs

MICROMETER TORQUE WRENCHES

- Dual scale torque wrench.
- Micrometer adjusting, reversible ratcheting.
- Complete with conversion table chart.
- Lock holds torque setting.
- Chrome plated alloy steel.

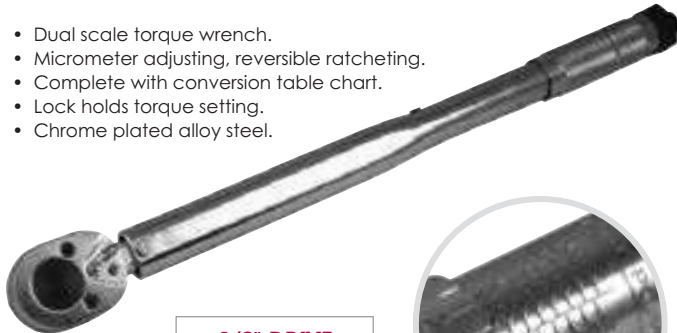

1/2" DRIVE TORQUE RANGE 7020-0150

10-150 ft./lbs (1.4-20.7 m/kg)



9PC T-HANDLE TORX KEY SET

- Industrial grade heat treated extrude S-2 alloy steel.
- PVC coated handles provide a non-slip grip.
- Arm reach: 7-1/2".
- Complete with vinyl pouch.



9 PC SET 7900-0001

T10, T15, T20, T25, T30,
T40, T45, T50 & T55



COMBINATION WRENCHES

- Polished heads and raised panel.
- Forged steel.
- Open end and 15° offset box opening.



Inch

Item#	Size	OAL
7023-1001	1/4	4
7023-1002	5/16	4.6
7023-1003	3/8	4.8
7023-1004	7/16	4.5
7023-1005	1/2	5.9
7023-1006	9/16	6.3
7023-1008	5/8	6.7
7023-1009	11/16	7.5
7023-1010	3/4	8.2
7023-1011	7/8	10.6
7023-1012	15/16	11
7023-1017	1	10.7
7023-1018	1-1/16	13.6
7023-1019	1-1/8	13
7023-10191	1-3/16	15
7023-1020	1-1/4	13.4
7023-1021	1-5/16	16.8
7023-1022	1-3/8	17.5
7023-1023	1-7/16	18
7023-1024	1-1/2	18.7
7023-1025	1-5/8	19.6
7023-1026	1-11/16	20.2
7023-1027	1-3/4	21.2
7023-1028	1-13/16	22.7
7023-1029	1-7/8	22.4
7023-1030	2	23.5
7023-1031	2-1/8	24.2
7023-1032	2-1/4	25
7023-1033	2-3/8	26
7023-1034	2-1/2	26.7

MM

Item#	Size	OAL (Inch)
7023-2012	6	4.2
7023-2013	7	4.4
7023-2014	8	4.2
7023-2015	9	4.8
7023-2051	10	4.4
7023-2052	11	4.6
7023-2016	12	5.7
7023-2053	13	5.8
7023-2017	14	6.3
7023-2018	15	8
7023-2020	16	8
7023-2021	17	7.6
7023-2022	18	8.6
7023-2023	19	8.3
7023-2024	20	10
7023-2025	21	10
7023-2054	22	10.8
7023-2026	23	11.3
7023-2027	24	11.5
7023-2028	25	12.5
7023-2030	26	13.5
7023-2031	27	12.3
7023-2034	28	14.8
7023-2035	29	14.8
7023-2036	30	13.3
7023-2038	32	13.5
7023-2040	34	16.4
7023-2042	36	17

COMBINATION WRENCH SETS

- Forged chrome plated tool steel.
- All sets fully polished.
- With pouch.



14 PC SET 3/8~1-1/4"

7023-0005

3/8, 7/16, 1/2, 9/16, 5/8, 11/16, 3/4,
13/16, 7/8, 15/16, 1, 1-1/16, 1-1/8, 1-1/4"

15 PC SET 6~24MM

7023-0006

6, 7, 8, 9, 10, 11, 12, 13, 14, 15, 17,
19, 21, 22, 24mm

HANDLES & KNOBS

ADJUSTABLE HAND LEVER WAND KNOBS -Hex Head

- Handle Material: Plastic (KT)



Item#	Female Thread	Hex (mm)	Handle Length L
8017-0048	M6X1.5	14	1.65"
8017-0051	M8X1.25	14	2.83"
8017-0053	M10x1.5	16	3.62"

LEVER WAND KNOBS-Push to Screw On

- Handle Material: Plastic (KT)



Item#	Thread x Length	Handle Length (mm)
8017-0060	M6x20mm	43
8017-0061*	M6x20mm	63
8017-0063	M6x30mm	43
8017-0064	M6x30mm	63
8017-0066	M6x45mm	43
8017-0070	M8x15mm	83
8017-0071	M8x30mm	63
8017-0073	M8x40mm	83
8017-0076	M10x20mm	83

*Limited Supply

REVOLVING HANDLES

- Handle Material: Bakelite (KU)



Item#	Thread x Length	Handle Length (mm)	Handle Dia (mm)
8017-0080	M8x13mm	56	20
8017-0082	M8x13mm	76	22
8017-0085	M10x13mm	56	20
8017-0086	M10x13mm	76	22
8017-0087	M10x13mm	83	25

FLAT END HANDLES, REVOLVING

- Material: Steel
- Fits most movable handwheels

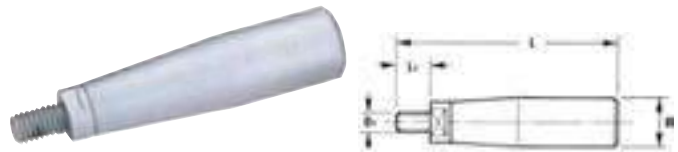

Item#	Thread D1	Dimensions (mm)		
		D	L1	L
8017-0001	M10X1.5	23	16	100
8017-0002	3/8"-16	22	16	99

ELLIPSE END HANDLES, REVOLVING

- Material: Steel
- Fits most movable handwheels

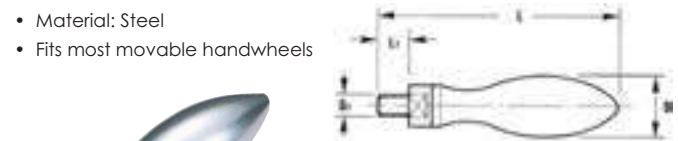

Item#	Thread D1	Dimensions (mm)		
		D	L1	L
8017-0010	M6x1.0	16	7	60
8017-0011	M8x1.25	20	9	80
8017-0012	M10x1.5	26	13	110
8017-0016	3/8"-16	25	13	99

ADJUSTABLE FACE SPANNER WRENCHES

- Ideal for adjusting collars, lock nut rings & bearings
- Black finish.

NEW



MADE IN TAIWAN

Item #	Pin Hole Dia. D	(mm) Length	Adj. Range Between Pins
7016-0040	3.0	7.5	7-40
7016-0042	4.0	7.3	11-60

KNURLED KNOBS

- Ideal for adjusting collars, lock nut rings & bearings
- Black finish.

NEW



Item#	Thread	Base Dia.	Diameter
8017-0120	10-24NC	3/4"	5/8"
8017-0123	1/4"-20NC	1"	3/4"
8017-0125	3/8"-16NC	1-1/4"	1-1/8"

KNOB HAND

- Material: KT plastic
- Thread: M8x1.25, 0.83" length
- Knob: 1.6" diameter, 2.6" Length.



8017-0042

BALL KNOBS

- Material: Bakelite (KU)



Item#	Diameter (mm)	Thread
8017-0030	25	M6
8017-0032	25	M8
8017-0033	38	M8
8017-0035	38	M10
8017-0037	38	M12
8017-0038	42	M12

SAFETY SWIVEL HOIST RINGS

200% PROOF-LOAD TESTED AND CERTIFIED WITH TRACEABLE SERIAL NUMBER

- Swivels 360° - pivots 180°
- Material: Alloy Steel
- Safety factor: 5:1
- Finish: Black Oxide (Also available: Cadmium Plated, Electroless Nickel Plated, Zinc Plated)
- Magnetic partical inspected.
- Certified heat treatment.
- Rated at 100% from 0° to 90°
- Fatigue tested to 20,000 cycle at 1.5 times the rated load
- Thread: Longer Projection and Fine Threads Available.
- Comforms to CE.
- **Meets or exceeds the requirements of ASME B30.26**

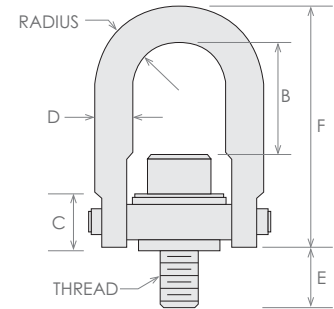
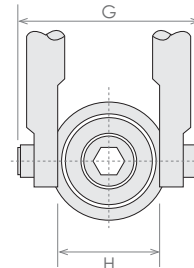

INCH THREAD

Rated Loads(Lbs)	Thread Size	A	C	D	E	Standard U-Bar Item#	B	F	G	H	Torque Ft/#	Wt. (Lbs)
600	1/4~20	0.43	0.71	3/8	0.54	8004-6100	1.27	2.67	1.84	1.00	6	0.3
800	5/16~18	0.43	0.71	3/8	0.54	8004-6104	1.27	2.67	1.84	1.00	7	0.3
1,000	3/8~16	0.43	0.71	3/8	0.54	8004-6106	1.27	2.67	1.84	1.00	12	0.3
2,500	1/2~13	0.70	0.93	1/2	1.07	8004-6602	1.84	3.77	2.58	1.49	28	1.0
2,500	1/2~13	0.88	1.22	3/4	0.78	8004-6008	2.31	4.78	3.52	1.99	28	2.6
4,000	5/8~11	0.88	1.22	3/4	1.03	8004-6004	2.18	4.78	3.52	1.99	60	2.6
5,000	3/4~10	0.88	1.22	3/4	1.03	8004-6014	2.06	4.78	3.52	1.99	100	3.0
7,000	3/4~10	1.40	1.71	1	1.54	8004-6206	3.06	6.52	5.14	3.00	100	7.0
8,000	7/8~9	1.40	1.71	1	1.04	8004-6202	2.93	6.52	5.14	3.00	160	7.0
10,000	1~8	1.40	1.71	1	1.29	8004-6210	2.81	6.52	5.14	3.00	230	7.5
10,000	1-1/8~7	1.40	1.71	1	2.29	8004-6216	2.69	6.52	5.14	3.00	230	7.5
10,000	1-1/8~8	1.40	1.71	1	2.29	8004-6217	2.69	6.52	5.14	3.00	230	7.5
15,000	1-1/4~7	1.75	2.11	1-1/4	1.89	8004-6802	4.12	8.73	6.50	3.76	470	14.0
20,000	1-3/8~6	2.00	2.40	1-1/2	2.50	8004-6702	5.50	10.20	7.46	4.31	540	23.0
24,000	1-1/2~6	2.25	2.81	1-3/4	3.20	8004-6404	6.41	12.47	8.55	4.87	800	34.0
24,000	1-3/4~5	2.25	2.81	1-3/4	3.20	8004-6408	6.16	12.47	8.55	4.87	800	34.0
30,000	2~4-1/2	2.25	2.81	1-3/4	3.20	8004-6400	5.91	12.47	8.55	4.87	800	36.0
50,000	2-1/2~4	3.00	4.09	2-1/4	4.00	8004-7006	8.03	16.87	11.67	6.52	2100	88.0

STAINLESS STEEL AVAILABLE.

METRIC THREAD

Rated Loads(Lbs)	Thread Size	A	C	D	E	Standard U-Bar Item#	B	F	G	H	Torque Ft/#	Wt. (Lbs)
400	M8x1.25	11	18	10	13	8004-6912	32	68	47	25	9	0.4
500	M10x1.50	11	18	10	18	8004-6916	30	68	47	25	16	0.4
1,050	M12x1.75	18	24	13	27	8004-6608	48	96	66	38	37	1.0
1,050	M12x1.75	22	30	19	19	8004-6924	60	121	89	51	37	2.5
1,050	M14x2.00	22	30	19	29	8004-6928	58	121	89	51	40	2.5
1,900	M16x2.00	22	30	19	29	8004-6930	56	121	89	51	80	2.7
2,150	M20x2.50	22	30	19	34	8004-6936	52	121	89	51	135	6.7
3,000	M20x2.50	36	43	25	32	8004-6942	78	166	131	76	135	7.0
4,200	M24x3.00	36	43	25	37	8004-6948	74	166	131	76	311	15.0
7,000	M30x3.50	45	54	32	42	8004-6956	106	222	165	95	637	15.0
7,000	M33x3.50	45	54	32	67	8004-6960	103	222	165	95	637	23.0
10,000	M33x3.50	50	62	38	58	8004-6961	140	259	189	109	637	35.0
11,000	M36x4.00	57	71	44	63	8004-6966	166	317	217	124	1085	36.0
12,500	M42x4.50	57	71	44	83	8004-6968	160	317	217	124	1085	38.0
13,500	M48x5.00	57	71	44	83	8004-6970	154	317	217	124	1085	38.0
13,500	M56x5.50	57	71	44	88	8004-6973	154	317	217	124	1085	38.0
22,300	M64x6.00	76	103	57	101	8004-6972	204	428	296	165	2847	86.0

STAINLESS STEEL AVAILABLE.

48" PAN & BOX BRAKE

- 48" width is suitable for many metal forming operations.
- Hardened steel box fingers are easily removed or repositioned.
- Left and right beam control levers for easy operation.
- Large contour balanced brake handle for brake past 90° to 135°.
- Ruggedly built.

SPECIFICATIONS	
Capacity (mild steel).....	16 gauge
Brake range.....	0~135°
No. of finger.....	2"/5, 3"/6, 4"/5
Footprint.....	52" x 12"
Weight.....	368 lbs.



8600-4032

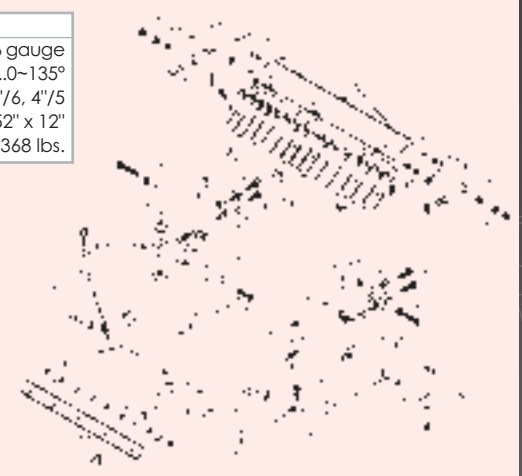

HEAVY DUTY BENCH GRINDERS

- Direct drive motor with no brushes or belts to adjust or replace
- Permanently lubricated motor bearings
- Adjustable shatter-resistant plastic eye shields
- Removable wheel covers for easier wheel changes
- Free speed: 3,500 RPM
- Adjustable tool rests
- Power: 110 V/ 1Phase
- 6' wire cord
- UL approved

COLOR MAY VARY

6", 1/2 HP
7600-0030

8", 3/4 HP
7600-0028



PEDESTAL STAND FOR BENCH GRINDERS

- For 6, 8 & 10" grinders
- Base for Grinder : 9-3/4 x 9-3/4"
- Overall height: 34"
- Weight: 22 Lbs.
- Coolant tank and adjustable tool tray.

8071-0034



HEAVY DUTY PEDESTAL BENCH GRINDER STAND

- Designed to accommodate 6", 7", 8", and 10" bench grinders and bench buffers, and 1", 2" and 4" belt grinders.
- Base and top are made of heavy-duty cast iron
- Top size: 10-5/8x10-5/8"
- Steel column is 3-1/2" diameter
- Adjustable height water pot provides quenching for work piece.
- Unique design allows mounting with 4 bolts, Mounting slots are 1/2" width & mounting holes are 1/2" diameter.
- Stand Height: 33"
- Pedestal leg length: 9.5"
- Weight: 58 lbs.

8071-0035



DELUXE HEAVY DUTY DIGITAL MULTIMETER

- 1" height digit LCD display.
- AC current 200mA/100μA, 20A/10 mA.
- AC voltage up to 750V/1 V.
- DC voltage up to 1000V/1V.
- DC current 200μA/100mA, 200mA/100μA, 20A/10mA.
- Data-held & diode test feature.
- LCD back light for dark places easy reading.
- Single standard 9-volt battery (not included).
- Resistance up to 200 mΩ
- Test leads.
- Logic test.
- Auto power off.

8070-0403



Limited Supply!

DIGITAL MULTIMETER

- Power: single standard 9V battery (not included).
- 200 mA range continuity indication.
- LCD display with max. 1999 reading.
- DC/AC voltage to 750V.

8070-0400

Limited Supply!



MINI UNIVERSAL BENDER - Forms Wire, Flat Metal & Tubing

- Forms wire, flat metal and tubing into clamps, handles, brackets, hooks, coils and more.
- Makes sharp angle bends up to 5/16" diameter rod and 1"x1/8" flat metal.
- Made of hardened tool steel.
- Mounts on a work bench or held in a vise.

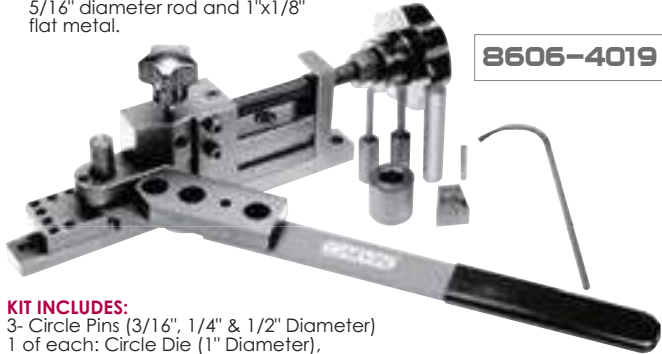

8606-4019

KIT INCLUDES:

3- Circle Pins (3/16", 1/4" & 1/2" Diameter)
1 of each: Circle Die (1" Diameter),
Stop Pin & Sharp Angle Die

TUBE NOTCHERS

- Operated on tubes with up to .118" wall thickness for steel.
- Advantage for joining and welding of tubes at a 90° angle.
- One device covers several tube diameters.
- Horizontal and vertical operation.
- Suitable for double-connections.

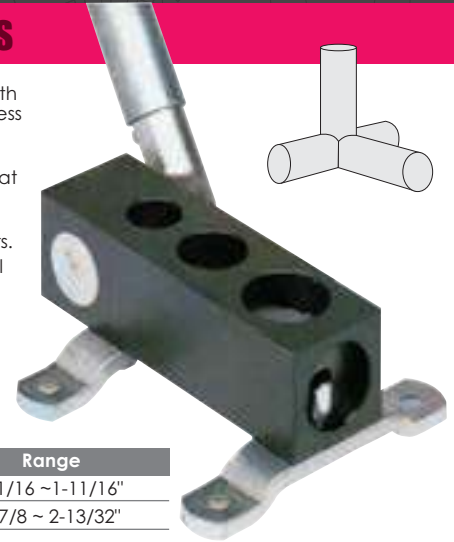

Item#	Range
8600-4046	1-1/16 ~ 1-11/16"
8600-4047	1-7/8 ~ 2-13/32"

8" BENCH METAL SHEAR

- Heavy duty structure.
- Can be used to cut sheet steel, steel bars and rods.
- Small and unique device for convenient site working.
- An adjustable hold-down clamp aids in securing material.

Limited Supply!



Item#	Blade Length	Capacity to Cut Round (Dia)	Plate	Wt. (lbs.)
8600-4005	8"	1/2"	1/4"	38

HEAVY DUTY ARBOR PRESSES

- Heavy duty frame.
- Precision made.
- 4 position steel anvil.
- Steel pinions.



Item#	Press (Ton)	Max. A	Press Ht. G	Base ExF	Capacity Over Table C	Capacity Over Anvil D	Ram	Wt. (lbs.)
8600-0031	1/2	3.54"	10.24"	4.35 X 9.53"	4.33"	3.62"	3/4"	24
8600-0032	1	4.29"	13"	5.04 x 10.63"	5.63"	4.84"	1"	35
8600-0033	2	4.52"	17.72"	6.77 x 16.93"	8.44"	7.68"	1-1/4"	91
8600-0035	5	7.87"	33.67"	10.95x25.59"	18.76"	17.72"	2"	360

HHIP HEAVY DUTY ARBOR PRESSES



- Heavy duty frame.
- Precision made.
- 4 position steel anvil.
- Steel pinions.



Item#	Press (Ton)	A	B	Capacity Over Anvil C	(Inch) Capacity Over Table D	F	E	Anvil H	Wt. (lbs.)	
8600-1031	1/2	10.20	9.25	2.95	3.69	3.54	4.17	2.36	2.68	18
8600-1032	1	12.80	10.63	3.94	4.68	4.92	5.12	2.95	3.35	33
8600-1033	2	17.91	16.93	5.91	6.68	6.50	6.50	3.94	4.72	69

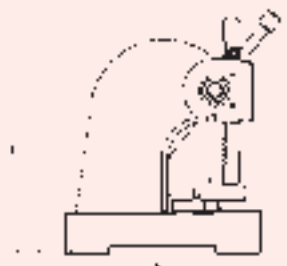

ARBOR PRESSES

Pro-Series ARBOR PRESSES-With 3PC Punch Set

- For riveting, squeezing, punching, bending, and other pressing applications.
- Base drilled for mounting on bench or pedestal.
- Sturdy, cast-iron construction.
- Removable machined steel anvil provides accurate work support in four slot positions.
- Rugged steel ram is driven by machined pinion.
- Punches or tools may be added to the end of the ram with the aid of a magnetic insert.



Item#	Press (Ton)	High Speed Wheel	Max. D	Press Ht. A	Capacity Over Anvil C	Anvil Dia. H	Ram	B	E	J	Weight (lbs)
8600-0130	1/2	No	3.3"	11"	4.6"	3-1/2"	3/4"	9.5"	5	2	20
8600-0131	1	Yes	4"	14"	5.5"	4-1/2"	1"	16"	8	2-1/8"	33
8600-0132	2	No	6"	18"	8.52"	6-3/4"	1-1/4"	18"	9-1/2"	3-1/8"	71
8600-0133	3	No	9"	36"	18"	6-3/4"	1-1/2"	21"	10	4	105

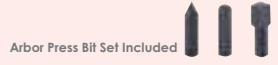

RATCHET LEVER ARBOR PRESSES

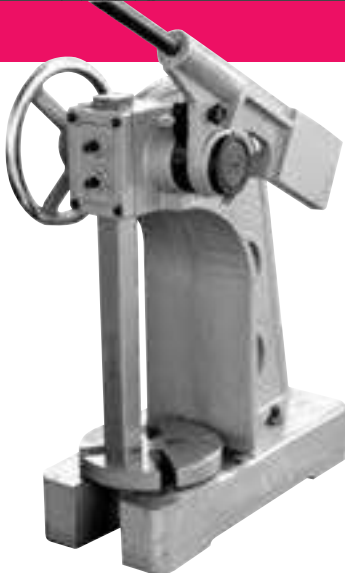

- Ratchet device permits lever to be used in most convenient position.
- Heavy-duty casting frame.
- 4-position anvil.
- Hand wheel advances ram to work quickly.

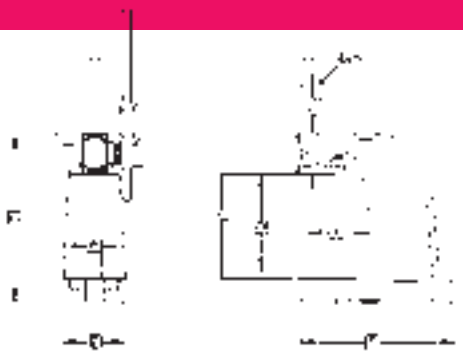

RATCHET TYPE

Item#	Capacity (Ton)	Height of Press G	Max. A	Arbor	Ram	Capacity Over Anvil D	Base E x F	Weight (lbs)
8600-3301	2	18-1/2"	6"	1-7/8"	1/1/4"	8-1/2"	11.0x17.3"	86
8600-3401	3	21-1/2"	6"	1-3/4"	1-1/2"	12-5/8"	10.7x17.5"	132
8600-3501	5	35"	8.5"	2"	2"	15"	14.6x25.4"	440

RATCHETING GEARS & REPLACEMENT RINGS FOR ARBOR PRESSES

- Original replacement parts.
- Ring & ratcheting gear sold separately.
- Fits HHIP brand ratcheting arbor presses.

For Arbor Press Type	Ratcheting Gear Item#	Retaining Ring Item#
2 Ton	8600-3302	8600-3303
3 Ton	8600-3402	8600-3403
5 Ton	8600-3502	8600-3503



REPLACEMENT SPINDLE FOR 2 TON RATCHET ARBOR PRESS

- Original replacement parts.
- Fits HHIP brand ratcheting arbor press.
- Fits arbor press item#8600-3301.

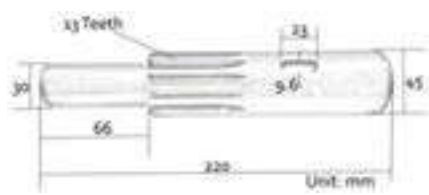

8600-3304

Pro-Series ARBOR PRESSES

- For riveting, squeezing, punching, bending, and other pressing applications.
- Base drilled for mounting on bench or pedestal.
- Sturdy, cast-iron construction.
- Removable machined steel anvil provides accurate work support in four slot positions.
- Rugged steel ram is driven by machined pinion.

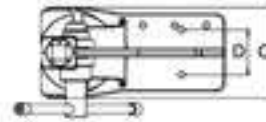
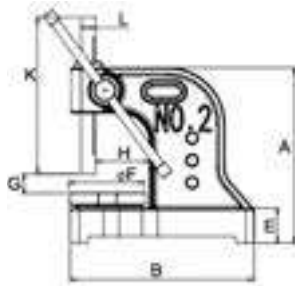

8600-1132 Shown

Item#	Press (Ton)	(MM)					Anvil Dia. F	Capacity Over Anvil G	H	K	Wt. (lbs)
8600-1130	1/2	A	B	C	D	E					
8600-1131	1	235	235	135	60	45	85	100	75	200	17
8600-1132	2	280	270	155	60	45	110	125	90	250	31
8600-1133	3	390	405	200	100	80	170	170	115	330	60
8600-1133	3	540	456	240	100	100	170	280	130	455	117
8600-1135	5	796	624	290	120	118	250	450	210	648	269

RATCHET 3TON ARBOR PRESS - Large Capacity

RATCHET TYPE



- Ratcheted lever lowers the ram to provide up to 3 tons of force.
- Handwheel quickly advances the ram for initial positioning, and the ratcheted lever lowers the ram onto the object and can be set at a comfortable position for the user.
- Smooth action gears enable fine control over ram movement with the lever.
- Counterweight repositions the lever to the top after a downstroke to reduce strain and quickly prepare for the next task.
- Open base and slotted table plate provide support for solid objects as well as an outlet for arbors and similar items to pass through.

8600-3603

Ratchet leverage arbor press with handwheel and counterweight applies up to 3 tons of force to facilitate installation, removal, and pressing of items. The handwheel advances the ram for quick placement near the object being pressed. The ratcheted lever lowers the ram onto the object with more precision and control than the handwheel and can be set at a comfortable position for the user. The smooth action gears enable fine control over ram movement with the lever, and a counterweight repositions the lever to the top after a downstroke to reduce strain and quickly prepare for the next task.

The open base and slotted table plate provide support for solid objects as well as an outlet for arbors and shafts to pass through. The plate can be removed or rotated to one of its 5 openings of varying diameters depending on the requirements of the application. The ram cap can be adjusted using the included 0.008" and 0.015" thick shims to adjust the ram forwards and backwards and to compensate for wear. The set screw adjusts the ram sideways. Three 0.52"-dia. holes are located on the base to enable bench mounting. Mounting hardware is not included. Press is assembled.

Item#	Press (Ton)	Max. Working Dia.	Max. Working Ht.	Throat Depth	(Inch) Press Ht.	Base Width	Base Depth	Ram	Leverage Ratio	Wt. (lbs)
8600-3603	3	14	17	7	27	10	21	1-1/4	48:1	145

PEDESTAL FOR ARBOR PRESS

- This arbor press floor pedestal is used with the Dake Model 1 or 1-1/2 (3 ton) arbor presses & our #8600-3603.
- Features slot to accommodate pieces that extend below the base.
- Anvil diameter word area 22-1/4".
- Weight: 70 lbs.
- Dimension(LxWxH): 12x21x36"

8600-3610



Pro-Series 3TON RATCHET LEVER ARBOR PRESS -LARGE CAPACITY

- 3 Ton capacity delivers the heavy force needed for riveting, squeezing, punching, bending, and other pressing applications.
- The Extra large clearance over the table allows for broaching or pressing larger items.
- It is counterweighted for a quick handle return and has a rapid ram feature that is advanced by using the press's convenient side-mounted handwheel.
- The rugged, reversible steel ram is driven by a machined piston, dimensions are 1-1/4 x 1-1/4 inches. Punches or tools may be added to the pre-drilled end of the ram with the aid of a magnetic insert. The three-bit set includes one-pointed bit, one round bit, and one square end bit along with a removable steel anvil.
- The removable 4-slotted anvil has a diameter of 8 inches.
- The Sturdy cast-iron base is pre-drilled for mounting on either a bench or pedestal (HHIP #8600-3610), and it is also machined to hold the included three-bit punch set.
- All parts are interchangeable with PALMGREN RP30.

RATCHET TYPE

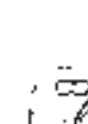
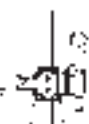

Item#	Capacity (Ton)	A	B	C	D	Ram E	Ram Punch Hole Dia.	G	Capacity Over Table H	Wt. (lbs)
8600-4401	3	21-1/4	9-7/8	27-3/4	7-13/16	1-1/4x1-1/4	1/2	6-7/8	17"	130

1-2-3 Blocks.....73-74, 216
 2-3-4 Blocks.....74
 2-4-6 Blocks.....74
 2-Jaw Chucks.....295
 3-Jaw Chucks.....285-287,
 290, 292-293, 295
 4-Jaw Chucks.....287-288, 294
 6-Jaw Chucks.....286, 290, 292
 40 Position Quick Change System...304

5C Tooling & Fixtures

Collets.....279-280
 Collet Bar Tool Holder.....299
 Collet Blocks.....237
 Collet Chucks.....234-236,
 279, 291
 Collet Rack.....279
 Emergency Collets.....280
 Fixtures.....276
 Indexer.....278
 Lathe Chucks & Mounts.....
 287-288, 290
 Spin Jig.....278
 Stops.....279
 Wrench.....279

A

A-Mount Back Plates.....294
 Acme Thread Gages.....31

Adapters and Arbors

Boring Head.....279-280
 BT.....225
 Circular Saw.....208
 Drill Chuck.....206, 222, 225
 End Mill.....126, 206, 208, 210,
 212, 213, 225, 226
 ER Holders.....207
 Expanding.....232, 282
 Grinding Wheel.....321-322
 Lathe Chuck.....289-292
 Milling Machine.....208
 Morse Taper.....208-211
 NMTB.....213-214
 R8.....207-208
 Revolving Tailstock.....306
 Slotting Saw.....208
 Stub.....208
 V-Flange.....221-223

Adjustable Blade Reamers...95
 Adjustable Dresser.....319
 Adjustable Link.....343
 Adjustable Parallels.....77
 Adjustable Round Split Dies..98
 Adjustable Tap & Reamer Wrenches..
 102
 Adjustable Tailstocks...269-270
 Adjuster, Magnetic Chuck Current...
 318

Air Accessories & Tools

Angle Grinders.....339-340
 Blow Guns & Kits.....338
 Connectors.....338, 341
 Collets.....340
 Drills.....340
 Filters & Regulators.....342
 Fittings.....341
 Grinders.....338-339

Guns.....338
 Impact Wrenches.....340
 Manifolds.....341
 Mufflers.....341
 Ratchet.....340
 Sander.....338
 Valves.....341
 Wrench.....340

Angle Blocks.....77, 81
 Angle Dressers.....316-317
 Angle End Mill Grinding Fixture...276
 Angle Gages.....29, 65
 Angle Grinders.....340-341
 Angle Plates.....77, 81-83, 268
 Angle Vises.....259, 265, 343
 Angle Vises, Welder's.....343
 Angle Lock Type Vises.....263
 Annular Cutters.....90
 Anvil Attachment Kits.....16
 Aprons.....342
 Arbor Presses.....354-356

Arbors

Drill Chuck.....168, 171,
 174, 181, 185, 198-199
 Expanding.....236
 Milling Machine.....170
 Revolving Tailstock (MT to JT)...242
 Slotting Saw.....116

Axial Support Bracket.....58

B

Backplates.....289-292, 306
 Ball Attachments, Micrometers...16
 Ball Nose End Mills.....114
 Ball Pein Hammers.....349
 Ball Plungers.....251
 Bars, Sine.....74
 Bases, Magnetic.....39-45
 Batteries.....10
 Bench Block.....345
 Bench Centers.....312
 Bench Grinders.....353
 Benders.....354
 Bevel Squares.....64
 Blade Micrometers.....23
 Blades, Cut-Off & Grooving...
 138-139, 141, 304
 Blind Hole Spotter Set.....348

Blocks

1-2-3, 2-3-4, 2-4-6.....27, 73-74
 Angle.....81
 Bench.....345
 Collet.....237
 Gages & Accessories...71-72
 Super Vee Block.....79
 Space.....74
 Test.....84
 V-Blocks.....79-80

Blow Guns.....336
 Bore Gages.....34
 Bore Gage Setting Master...34
 Boring Bars, Cobalt & Carbide
 Tipped.....121
 Boring Bars, Indexable...145-152
 Boring Bars, Double End...121

Boring Heads & Sets.....
 206, 244-248
 Boring Rings.....296
 Boring Shanks...202,245-246,248
 Boroscope, Video.....85
 Box & Pan Brake.....353
 Brake Dresser.....318
 Brass Hammers.....349
 Brazed Tool Bits & Sets.....119
 Broaches.....117-118
 Brown & Sharpe Collets.....212
 BT Tooling.....225-226, 234, 239
 Bull Nose Live Centers.....310
 Burrs, Carbide.....109

Bushings

Keyway.....118
 Tool Holder Sets.....281

C

Caliper Accessories.....10

Calipers

Batteries.....10
 Bluetooth.....4
 Caliper Cases.....10
 Dial.....7-9, 13
 Internal Dial Caliper Gage...48
 Depth Measuring Base...10
 Digital Electronic...1-6, 13-14
 Inside.....33
 Long Jaw.....5-6, 12
 Long Range.....4-6, 9, 12
 Outside.....33
 Plastic.....11
 Sets.....13-14
 Shock-Proof.....8
 Spring.....33
 Upper Jaws.....6
 Vernier.....11-13
 Waterproof.....3, 4, 6, 14
 Water Resistant.....2-4, 6

Cap Screw Counterbores...93
 Carbide Burrs.....109
 Carbide Drills.....88
 Carbide End Mills.....113

Carbide Inserts

A60.....195
 AG60.....195
 ANGX.....171
 APKT.....171
 CCGX.....171
 CCMT.....172
 CNMA.....172
 CNMG.....173-174
 CNMM.....175
 CPMT.....175
 Cut-Off.....136, 139, 199
 DCGX.....175
 DCMT.....175-176
 DNMA.....176
 DNMG.....176-178
 DPMT.....178
 Grooving...131, 134, 197-200
 GTN.....139, 199
 JCL.....143
 JCQ.....143
 KNUX.....178

Cases

Caliper.....10
 Gage Block.....71
 Micrometer.....16
 Pin Gage.....36

CAT ER Collet Chucks.....
 223, 234-236
 CAT End Mill Holders...221-222
 CAT Shell End Mill Holders...222
 CAT V-Flange Holders...221-222
 CBN Wheels.....320
 Center & Edge Finders...203-204
 Center Drills.....91
 Center Finder, Round Bar...63
 Center Keys.....243

MGMN.....138
 MRMN.....138, 200
 NOTCH.....135
 ONHU OCTAGON.....129
 RCKT.....178
 RCMT.....179
 RDKW.....179
 RNMG.....179
 SCMT.....179-180
 SD.....180
 SEAN.....180
 SEET.....180-181
 SEHT.....181
 SEKN.....181
 SNKN.....181
 SNMA.....181
 SNMG.....181-183
 SPG.....183
 SPKN.....184
 SPMR.....184
 SPMT.....184
 SPU.....184
 TCGX.....184
 TCMT.....185
 TDEX.....185
 TKEH.....136
 Threading.....
 131-132, 135, 195-198
 TNMA.....134, 186
 TNMC.....134, 186
 TNMG.....186-188
 TNMM.....188
 TPGB.....189
 TPGC.....189
 TPGH.....189
 TPGN.....189
 TPGW.....190
 TPKN.....190
 TPMC.....134
 TPMM.....190
 TPMR.....190
 TPU.....191
 TPUN.....191
 TT/TPMM.....190
 VBMT.....191
 VCMT.....192
 VCGX.....192
 VNMG.....192-193
 VNMS.....193
 WCMT.....193
 WCMX.....193
 WNMA.....194
 WNMG.....194-195

Centers

Bench.....312
 Dead.....306
 Live.....307-311

Chamfering Tools.....122
 Chuck Wrenches.....294
 Chucking Reamers & Sets...94

Center Line Gages.....10
 Center Gages.....30, 203
 Center Punch.....346
 Centered V-Magnet.....42
 Centering Indicators.....57

Centers

Bench.....312
 Dead.....306
 Live.....307-311

Chamfering Tools.....122
 Chuck Wrenches.....294
 Chucking Reamers & Sets...94

Chucks

CAT40.....223
 5C Collet...234, 236, 279, 291
 ER.....206-207, 223, 233-235
 Drill.....207, 225
 Lathe.....270, 275, 285-295
 Magnetic.....323-324
 Rotary Indexes.....271
 SK (Lyndex Style).....238

Circular Saw Arbors.....208
 Clamps, Dovetail.....59
 Clamping Kits.....249, 251-252
 Clamping Studs.....250
 Clamps for Indexable Tools..166
 Clamps, Hold Down.....252
 Clamps, Toggle.....254-258
 Claw Hammer.....349
 Clutch Collets.....278
 Collet Blocks.....237
 Collet Chucks.....
 210, 212, 214, 226, 233-235
 Collet Fixtures.....237, 278
 Collet Racks.....205-206, 279

Collets

5C.....278-280
 Air Tools.....340
 Brown & Sharpe.....212
 Chucks...206-207,210,233-237
 Clutch.....278
 Emergency (5C)280
 Expanding.....278
 ER.....227-230
 Flex, Tap.....103
 Hex (5C).....280
 Metric.....205, 227-228, 280
 Morse Taper.....209
 R8.....205
 Racks.....205-206, 232, 279
 Round.....278-280
 Rubber Flex.....103
 SK-10 & SK-16.....238
 Sleeves.....234
 Spring.....227-230
 Square.....280
 Step.....278

Collet Fixtures.....276
 Collet Indexer (5C).....278
 Collet Stops.....278-279
 Collet Wrenches.....231-232
 Combination Squares.....62
 Combination Wrenches...350
 Combined Drill & Countersinks...91

Comparators

Height Presetter.....	215-216
Optical.....	86
Compound Angle Plate.....	81
Compound Milling Tables.....	267
Compound Slide Tables.....	267
Concentricity Checker.....	313-314
Convex Radius Milling Cutters.....	114
Coolant Hose Kits.....	334-335, 337
Coolant Hose Wrenches.....	337
Coolant Pump Kit.....	335-336
Connectors, Coolant.....	337
Console, Digital.....	202
Controller, Magnetic Chuck.....	318
Counters.....	349
Counterbores.....	92, 93
Countersinks.....	91-93, 108, 122
Coupling Nuts.....	250-251
Couplers, Air.....	338
Cross Slide Vises.....	259
Cup Wheels.....	320
Current Adjuster, Magnetic Chuck.....	318
Cut-Off Blades.....	141, 304
Cut-Off Blades/Indexable.....	138-140
Cut-Off Inserts.....	138-140
Cut-Off Tool Holders.....	139-140, 304
Cut-Off Wheel Mandrel.....	339

Cutters & Saws

Annular.....	90
Chamfering.....	115
Disc.....	345
Double Angle Shank.....	115
Convex Milling.....	114
Convex Radius.....	114
Fly.....	120, 211
Gear.....	116
Plain Metal Slitting.....	116
Single Angle Chamfering.....	115
T-Slot.....	115
Woodruff Keyseat.....	118

Cylindrical Squares.....	64
--------------------------	----

D

D Mount Back Plates.....	291
D Mount Direct Mount Chucks.....	293-294
Dead Blow Hammers.....	349
Dead Centers.....	306
Deburring Tools.....	107-108
Deep Throat Micrometers.....	20
Demagnetizers.....	344
Depth Gages & Accessories.....	25-26
Depth Micrometers.....	25-26
Dial Bore Gages.....	34
Dial Calipers.....	7-9, 13
Dial Height Gages.....	67
Dial Indicators.....	13, 45, 47-51
Dial Protractor.....	60
Dial Test Indicators.....	13, 45, 54-56
Diamond Dressers.....	319
Diamond Needle Files.....	108
Diamond Pin Set.....	108
Diamond Wheels.....	320
Die Grinders.....	338-340

Die Holders.....	102
Die Sets.....	97-98
Die Stocks.....	102
Diemakers Square.....	64
Dies.....	97-98
Digital Electronic Calipers.....	1-6, 13-14
Digital Electronic Display.....	201-202
Digital Electronic Readout Scales.....	201
Digital Electronic Height Gages.....	68-69
Digital Electronic Indicators.....	45, 51-52
Digital Electronic Micrometers.....	21, 24, 26, 28
Digital Electronic Multimeters.....	353
Digital Electronic Protractor.....	61
Digital Electronic Thickness Gage.....	26
Disc Cutter Set.....	345
Dividers.....	33
Dividing Fixture, Wire EDM.....	330
Dividing Heads.....	274-275
Dividing Plates.....	268-270, 273
Double Angle Shank Cutters.....	115
Double End Boring Bars.....	121
Double Square.....	62
Dovetail Cutters.....	123
Drawbars.....	203
Drawbar Hammer.....	201

Dressers

Adjustable Diamond.....	319
Brake Truing.....	318
Diamond.....	319
Radius & Angle.....	316-317
Sine Dresser.....	317
Universal Wheel.....	316
Drift Keys.....	243
Drift Tool, Hand Dayton Style.....	209

Drill Chucks & Accessories

Arbors.....	206, 222, 225
Ball Bearing.....	241
Drill Chucks with Key.....	225, 241
Hand Drill Feed.....	240
Keyless Drill Chucks.....	207, 211, 221, 225, 239-240
Pin Chuck Set.....	242
Pin Vise Set.....	242
Replacement Keys.....	241
Wedge Sets.....	242
Wrenches.....	240
Drill Press Vises.....	259-260
Drilling Tables.....	267

Drills

Air.....	340
Annular.....	90
Carbide.....	88
Center.....	91
Cobalt.....	87-89
Jobber Length.....	87-89
Metric.....	87-89
NC Spotting.....	87
Sets.....	87
Silver & Demming.....	89

Solid Carbide.....	88
Spotting.....	87
Step.....	94
Tap & Drill Set.....	88
Taper Shank.....	89
Wire Gage.....	87

Drill Press Center Finder.....	203-204
Drive Pin Punch Sets.....	346
Dovetail Clamps.....	59
Dykem.....	343

E

Edge and Center Finders.....	204
Electrical Tape.....	342
Electronic Digital Caliper.....	1-6, 13-14
Electronic Digital Depth Gages.....	26
Electronic Digital Indicators.....	45, 51-52
Electronic Digital Height Gages.....	68-69
Electronic Digital Micrometers.....	21, 24, 26, 28
Emergency Collets (5C).....	280
End Mill Grinding Fixture.....	276
End Mill Holders.....	126, 206, 208, 210, 212-213, 225-226

End Mills

AlTiN Coated.....	110-113
Ball Nose.....	114
Carbide.....	113
Center Cutting.....	111-114
Chamfering.....	122
Cobalt.....	111-114
Corner Rounding.....	110
Double End.....	110-111
Fine Pitch.....	113
High Speed Steel.....	110-112, 114
Indexable.....	122, 124-128
Miniature.....	111
Roughing.....	113
Sets.....	110, 114
Single End.....	110, 112
Square Shoulder.....	128
Titanium (TiN) Coated.....	110-113

ER Tooling

BT.....	226, 233-236
CAT40.....	223, 234-236
Collets.....	221-230
Collet Blocks.....	237, 276
Collet Chucks.....	223, 233-235
Collet Fixtures.....	237, 291
Collet Racks.....	232
Fixtures.....	237
Morse Taper.....	210, 234-236
NMTB.....	213-214, 233, 235-236
Nuts.....	231
Punch Formers.....	315
R8.....	233, 235-236
Replacement Nuts.....	231
Straight Shanks.....	233, 235-236
Wrenches.....	231-232

Exhaust Mufflers.....	341
Expanding Arbors.....	232, 282
Expanding Collets.....	278
Expanding Mandrels.....	282
Extractors, Screw.....	109

F

Face Mill Holders.....	212
Face Mills.....	126-130
Face Mill Screws.....	165
Feeds, Power Table.....	202
Files, Riffler, Needle & Steel.....	108
Filter/Regulator/Lubricator Units.....	342

Finders

Center.....	203-204
Edge.....	204
Round Bar Center.....	63

Fittings

NPT Sintered Bronze Exhaust Mufflers.....	341
Push to Connect.....	341
Fixture, EDM Dividing.....	330
Fixtures, Tightening.....	215, 221, 224
Flanged Nuts.....	250-251
Flanges, Grinding Wheel.....	321-322
Flexible Arm Magnetic Bases.....	42
Floating Die Holders.....	102
Fly Cutters.....	120, 211
Frame Levels.....	66

G

Gage Block Set Repl. Cases.....	71
Gage Blocks & Accessories.....	71-72
Gage Handles.....	36

Gages

Angle.....	29, 65
Bore, Dial.....	34
Bore Gage Setting Master.....	34
Center.....	30, 203
Center Line.....	10
Convex & Concave.....	29
Depth.....	25-26
Dial Thickness.....	26
Electronic.....	26
Height.....	67-69
Internal Caliper.....	33
Monoblock Depth Vernier.....	25
Multipurpose, 7-in-1.....	30
Pin/Plug.....	35-38
Planer and Shaper.....	81
Radius.....	29
Screw Pitch.....	31
Screw Thread ACME.....	30
Small Hole.....	33
Surface.....	70
Surface Specimens.....	84
Surface Roughness.....	84
Telescoping.....	32-33
Thread & Ring Gages.....	31
Thickness.....	26
Wire Measuring.....	16, 30

Gears & Rings for Arbor Presses.....	355
Giant Slotted Angle Plates.....	83
Granite Checks.....	43
Granite Squares.....	64
Granite Surface Plate Stands.....	70
Granite Surface Plates.....	70

Grinders

Angle.....	339
Air.....	338-339

Bench.....	353
Punch.....	315
Stand.....	353

Grinding Driving Carriers.....	319
Grinding Fixture.....	276
Grinding Wheel Adapters.....	321-322
Grinding Wheel Dressers.....	319
Grooving Tool Holders.....	133-137

H

Half-Round Combination Holder.....	58
Halogen Work Lights.....	332
Hammer / Wrench.....	201
Hammers.....	349
Hand Notcher.....	354
Hand Tappers.....	101, 103-104
Hand Taps.....	96-97

Handles

Ball Knobs.....	351
Machine Levers.....	351
Pin Gage.....	36
Quill Feed Adapter.....	202
Quill Feed.....	201
Vise.....	263

Hard Jaws for Lathe Chucks.....	261-262
Hardness Tester & Accessories.....	84
Height Gage Clamps & Scribes.....	59
Height Gage Attachment.....	59, 67-69
Height Gages.....	67-69
Helicoil Style Thread Repair Kits.....	105-106
Hex Collets.....	280
Hex Dies.....	97-98
Hex Nuts.....	250
Hex Wrenches.....	165
Hi Spot Blue.....	343
Hoist Rings.....	352
Hole Mike Sets.....	28

Holders

Magnetic.....	39-45
End Mill.....	214, 221-222, 226
Indicator.....	39-43
Hold-Down Clamps.....	252
Hole Spotter Set.....	348
Horizontal & Vertical Collet Indexer.....	278
Hoses, Coolant.....	337
HSK ER Collet Chucks.....	212
HSK Face Mill Holders.....	212

I

Impact Wrenches.....	340
----------------------	-----

Indexable Tooling

Boring Bars.....	145-152
Carbide Insert.....	See Carbide Inserts
Countersinks.....	122
Cut-Off Tools.....	139-141, 143
Dovetail Cutters.....	123
End Mills.....	122, 124-128
Face Mills.....	126, 130
Grooving Holders.....	133-137
Integral Shank.....	140
Parting.....	137

INDEX

Spare Parts.....165-166
T-Slot.....123
Threading Tools.....132-137
Turning Tools.....
.....119, 132, 142-144, 153-164

Indexer, 5C.....278
Indexer, Rapid.....271
Indexing Fixtures.....273
Indexing Fixture, Rotary.....273
Indexing Quill Feed Handles...201
Indexing Spin Jigs.....277-278
Indicating Micrometers.....23

Indicator Accessories

Axial Support Bracket.....58
Back Covers.....48
Clamps.....58-59
Contact Points.....46
Conversion Point.....46
Extension Points.....46
Holders.....42-43, 58
Interapid Type Parts.....55
Magnetic Backs.....42, 44
Point Sets.....44, 46
Sets.....44-45, 58
Stands.....42-43
Universal Arms.....58

Indicators

Back Plunge46
Centering.....57
Dial.....44-45, 47-50
Dial Test.....45, 54-55
Dial with Lifting Lever.....48
Digital Electronic.....45, 51-52
Double Range Dial Test.....56
Large Face.....54
Long Range.....55-56
Metric.....47, 50, 55
Sets.....13-14
Short Range.....46
Travel.....44-51
Test.....54-56
Vertical.....55
Waterproof.....48

Inserts, Carbide.....
.....See Carbide Inserts
Inserts, Thread Repair.....105-106
Inside Micrometers.....27-28
Inspection Parallels.....25
Inspection Tool Kits.....13-14
Integral Shank Drill Chucks.....
.....207, 211, 214, 225, 239-240

J

Jacks Machinists.....253
Jack Screw Set.....253
Jacobs Taper Arbors...206, 222, 225
Jaw Nuts & Screws.....296
Jaws, Lathe Chuck...290, 297-298
Jaws/Vise.....261-262
Jobber Length Drills.....87

K

Keyless Drill Chucks.....239-240
KDK Style Quick Change Holders..
.....299-300

Keys

Drift/Center.....243
Drill Chuck.....241
Hex.....165
Lathe Chuck.....294
Torx.....350

Keyway Broaches/Bushings..117-118

Knobs

Hand.....351
Toggle.....217-220

Knurling Tools & Knurls.....305

L

L Mount Backplates.....291
Lamps.....See Lights
Latch Toggle Clamps...254-258
Lathe Centers.....306-311

Lathe Chucks

2-Jaw.....295
3-Jaw.....
.....270, 275, 285-287, 290, 292-293, 295
4-Jaw.....287-288, 294
6-Jaw.....286, 292
5C Mount...287-288, 290-291
Backplates.....289, 291-292
Collet Chucks.....291
Front Mount.....275
Independent.....288, 294
Jaw Boring Rings.....296
Jaw Nuts & Screws...296
Morse Taper Mount.....290
Power.....295
Self-Centering.....
.....270, 275, 285-287, 290, 292-293
Replacement Jaws.....
.....290, 296-298
Wrenches.....294
Zero-Set292

Lathe Mandrels.....282

LCD Display.....201-202

LED Machine Lamps...331-333

Letter Stamps.....345

Leveling Mounts.....203

Levels.....66

Lights

Halogen.....85
LED Machine Lamps...85, 331-333
Magnetic Base Lamps...331
Microscope Lamps.....85
Waterproof.....85, 331

Linear Scales.....201-202

Live Centers.....306-311

Lock & Shim Pins.....166

Long Travel Indicators...55-56

M

Machine Counters.....349

Machine Lamps.....331-333

Machinery Mounts.....203

Machinist Squares.....63

Machinist's Jacks.....253

Machinist's Vises.....265

Magnetic Backs, Indicator...42, 44

Magnetic Bases.....39-45

Magnetic Chuck Parallels...318

Magnetic Chuck Controller...318

Magnetic Chuck Current Adjuster...318

Magnetic Chucks.....323-324

Magnetic Parallel Set....78, 80

Magnetic Sine Bar.....324

Magnetic Sine Plate.....324

Magnetic V Blocks.....80, 324

Magnetizer / Demagnetizer...344

Magnets & Holders.....343

Magnifiers.....85-86, 331-332

Mandrels

Cut-Off Wheel.....339
Expanding.....282
Lathe.....282

Manifolds.....342

Markers, Industrial.....343

Master Precision Levels...66

Measuring Sets/Kits.....60

Metric Drills.....87-89

Metric Taps.....96

Micro Checking Sets.....15

Micrometers

Accessories.....15-16
Anvil, Interchangeable...20
Ball Spherical Face.....21
Blade.....23
Deep Throat.....20
Depth.....25-26
Digital.....20
Electronic Digital.....
.....21, 24, 26, 28
Heads.....20
Indicating.....23
Inside.....27-28
Metric.....19
Outside.....17-19, 24
Pointed Spindle & Anvil...22
Screw Thread.....21
Sets.....13-14, 17-19
Vernier Spline.....22

Micrometer Accessories

Anvil Attachments.....16
Ball Attachments.....16
Bases & Stands.....39-42
Metal Cases.....16
Stands.....16, 24
Thread Triangle.....15

Micrometer Measuring Masters...16

Micrometer Stands.....16, 24

Microscopes.....85-86

Mig Welding Pliers.....345

Milling and Drilling Tables...267

Milling Cutters.....114

Milling Machine Arbors...208

Milling Machine Draw Bars...203

Milling Vises.....263-265

Mirror, Inspection.....285

Mist Coolant Units.....334-337

Mity-Mag Indicator Holder...42, 44

Morse Taper Tooling

CAT40.....222, 234

Collets.....209

Collet Chucks.....210, 234-236

Dead Centers.....306

Die Holders.....211

Drill Chucks & Arbors...209, 211

End Mill Holders.....210

Extension Sockets.....209

Lathe Chucks.....290, 306

Live Centers.....307-311

R8.....209

Revolving Tailstock Backplates...306

Revolving Tailstock Chuck Adapter...
.....211

Sleeves.....209, 243

Tail Stock Turret.....290, 306

Mounts, Machine.....203

Mufflers, Exhaust.....341, 353

Multimeters.....353

N

NC Spotting Drills.....87

Needle Files.....108

NMTB Drill Chuck Arbors...213

NMTB End Mill Holders...213

NMTB ER Collet Chucks.....
.....213-214, 233, 235-236

Notchers.....354

Number Stamps.....345

Nuts

Coupling.....250-251
Flange.....250-251
Heavy Duty Hex.....250
Jaw Nuts & Screws...296
T-Slot.....250-251

O

Optical Comparator.....86

Optical Punch Set.....90, 345

Outside Micrometers...17-19, 24

P

Pan & Box Brakes.....353

Parallels & Sets.....75-77, 80

Parallel Cut-Off Blades...141, 304

Parting Tools.....137-141

Parts for Turning Tool Holders...
.....165-166

Permanent Magnetic Chucks...
.....323-324

Pilot Counterbores.....93-93

Pin Chuck Set.....242

Pin Vise Set.....242

Pin Gage Cases.....36

Pin/Plug Gages.....35-38

Pin/Plug Handles.....36

Pin Punches.....346

Pipe Dies.....97

Pipe Taps.....97

Pipe Jaws/Lathe...291, 296-298

Pipe Reamers.....94

Planer & Shaper Gage.....81

Plates, Angle.....81-83, 268

Pliers, Welding.....343

Plug Gages.....35-38

Plungers, Ball.....251

Pocket Comparator.....86

Point Sets, Dial & Test Indicator...
.....44, 46

Power Chucks.....295

Power Table Feeds.....202

Presettlers.....215

Presses, Arbor.....354-356

Protractors.....60-62, 65

Pumps, Coolant.....335-336

Punch Formers.....315-316

Punch Grinders.....315

Punches.....344, 346-348

Q

Quick Change Tool Posts,
Holders & Sets.....299-304

Quick Clamp for Mill Vise...262

Quick Clamp Work Stop...262

Quick Coupler.....338

Quill Feed Adapter.....202

Quill Feed Handles.....201

Quill Stops.....201

Quill Indicator Holder.....58

R

R8 Collet Racks.....205-206

R8 Tooling

Collet Chucks...207, 235-236

Collets.....205

Drill Chucks & Arbors...206-207

End Mill Holders.....206, 208

ER Holders & Sets.....
.....207, 233, 235-236

Indexable End Mill.....124

Morse Taper Sleeves...209

Right Angle Attachment...203

Saw Arbor.....208

Rack, Transfer Punch.....348

Radius Dressers.....316-317

Radius Gages.....29

Ratchet Arbor Presses...354-356

Ratchet & Tap Handles...102

Ratchet Wrench.....340

Readout Scales, Digital...201

Reamers.....94-95

Refractometers.....335

Regulators.....342

Replacement Draw Bar...203

Retention Knobs.....217-220

Revolving Tailstock Backplates...
.....290

Riffler File Set.....108

Right Angle Attachments.....
.....81-83, 203, 268

Right Angle Plates.....77

Ring Gages.....31

Rings, Boring.....296

Rings, Hoist.....352

Rockwell Hardness Tester...84

Rotary Chucks.....271

Rotary Indexer.....271

Rotary Table Flanges.....270

Rotary Tables.....268-272

Roughing End Mills.....113

Roughness Standards.....84

Round Head Protractors...60

Round Tool Bits.....120

Rules.....60

S

Safety Shields.....334

Sander.....338

Saws & Cutters

Convex Milling.....	114
Convex Radius.....	114
Double Angle Shank.....	115
Fly.....	120
Gear.....	116
Plain Metal Slitting.....	116
Single Angle Chamfering.....	115
Woodruff Keyseat.....	118

Saw Arbor, Slotting.....	116
Scales/Electronic.....	201-202
Scales/Rules.....	60
Scales/Linear.....	201-202
Scraper Set.....	100
Screw Bolts (Quick-Change).....	299, 302
Screw Extractors.....	109
Screw Jacks.....	253
Screw Pitch Gages.....	31
Screw Thread Micrometers.....	21
Screwless Vises.....	325

Screws

Jaw Nuts & Screws.....	296
Shell End Mill Holder.....	222
Tang for Drawbar End Holders.....	230

Scribers.....	346
Sensitive Hand Drill Feed.....	240
Shears.....	354

Sheet Metal Equipment

Benders.....	354
Brakes & Shears.....	354
Notcher.....	354
Pan & Box Brakes.....	353

Shell End Mill Holders.....	126
Shell End Mill Screws.....	222
Shields, Safety.....	334
Shim Pins.....	166
Shims.....	117, 166
Shop Apron.....	342
Shop Microscope.....	85-86
Silver & Deming Drills.....	89
Sine Bars.....	74
Sine Dresser.....	317
Sine Plates.....	81
Sine Vises.....	326, 328
Single Angle Chamfering Cutters.....	15
SK (Lyndex Style) Holders, Collet Chucks, Nuts & Sets.....	238
Sledge Hammer.....	349

Sleeves

Morse Taper.....	209, 243
R8 to Morse Taper.....	209

Slotted Angle Plates.....	83
Slotting Saw Arbor.....	208
Small Hole Gages.....	33
Sockets, Extension.....	209
Soft Jaws Lathe Chucks.....	290, 296-298
Soft Jaws for Vises.....	261-263
Solid Carbide Drills.....	88
Solid Carbide End Mills.....	113
Space Blocks.....	74
Spanner Wrenches.....	351
Specimens.....	84

Spin Jigs.....	277-278
Spindle Assemblies.....	255
Spindle for Arbor Press.....	355
Spindle Sqaure.....	203
Spindle Wipes.....	230
Spiral Taps.....	96
Spotters, Blind Hole.....	348
Spotting Drills.....	87
Spring Calipers & Dividers.....	33
Spring Collets.....	227-230
Springs.....	166
Square Head Protractors.....	60-62
Square Shoulder End Mills.....	128
Square Tool Bits.....	120

Squares

Bevel.....	64
Center Square.....	63
Combination.....	62
Cylindrical.....	64
Diemakers.....	64
Double.....	62
Granite.....	64
Machinist.....	60, 63
Solid.....	63
Spindle.....	203

Stamping Sets.....	345
--------------------	-----

Stands

Arbor Press.....	356
Bench Grinder.....	353
Granite Surface Plates.....	70
Indicator.....	42-43, 58
Micrometer.....	16

Steel Files.....	108
Steel Parallels.....	75-77
Step Collets.....	278
Step Drills.....	108
Stepped Angle Plates.....	82
Stereo Microscopes.....	85-86

Stops

Collet.....	278-279
Milling Vise.....	262
Quill.....	201
Work.....	262

Stub Milling Machine Arbors.....	208
Student Inspection Kit.....	13
Studs, Clamping.....	250
Super V Block.....	79
Super Spacer.....	273
Surface Plates, Granite.....	70
Surface Roughness Standards.....	84
Surface Specimens.....	84
Swivel Angel Plates.....	82
Swivel Clamps.....	59

T

T-Nut Blanks.....	299
T-Slot Bolts.....	250-251
T-Slot Clamping Kits.....	252
T-Slot Cleaner.....	252
T-Slot Cutters.....	123
T-Slot Nuts.....	250-251
Table Feeds.....	202

Tables

Compound Slide.....	267
Cross Slide.....	267
Milling and Drilling.....	267
Rotary.....	268-273
Tilting.....	268, 272

Tailstock Turrets.....	306
Tailstocks Rotary Table.....	269-270, 273
Tang Screws.....	230
Tangent Bar & Angle Block.....	77
Tap Wrenches.....	101
Tap Wrench Extensions.....	101
Tap & Drill Sets.....	88, 106
Tap & Die Sets.....	97, 99-101
Tape.....	342
Tape Measures.....	344
Taper Pipe Reamers.....	95
Tappers.....	101, 103-104
Tapping Guide.....	101-102
Tapping Heads.....	103
Taps.....	96-97
Tap Collets.....	103
Tap Holders.....	101-104
Telescoping Gages.....	32-33
Test Indicators.....	54-56
Thickness Gages.....	26
Thin Parallels.....	75-76
Thread Detective / Identifier.....	30
Thread Plug & Ring Gages.....	31
Thread Repair Kits.....	105-106
Thread Restoring Tool.....	108
Thread Triangle.....	16
Thread Wire Insert Installation Tool.....	106
Thread Wire Measuring Sets.....	16
Threaded Backplates.....	289
Threading Inserts & Grooving Inserts.....	131
Threading Tool Holders.....	132-137
Tie Downs.....	349
Tightening Fixtures.....	215, 221, 224
Tilt/Swivel Vises.....	259
Tilting Tables.....	268, 272
Toggle Clamps.....	254-258
Tool Bits.....	119-120
Tool Holder Bushings.....	281

Tool Holders

Boring.....	142-143, 145-152
Cut-Off & Grooving.....	139-141, 143
Grooving.....	133-137, 198-199
Integral Shank.....	140
Parting.....	137
Threading.....	132-137, 198-199
Turning.....	119, 132, 142-144, 153-164

Tool Posts & Sets

40 Position.....	304
Aloris Type.....	301-303
KDK Style.....	299-300
Miniature Sets.....	304
Quick Change Tool Posts/Sets.....	301-304
Toolmaker's Vises.....	325-329
Top Notch Style Tooling.....	135
Torque Wrenches.....	350
Torx Keys.....	350

Transfer Punches.....	348
Transfer Screws.....	347
Truing Dressers.....	318
Tube Notcher.....	354
Turning Tool Holders.....	119, 132, 142-144, 153-164
Turning Tool Sets.....	119-121
Turrets, Tailstock.....	306
Twin-Lock Vises.....	265
Tool Holder Bushings.....	281

U

Universal Angle Blocks.....	77, 81
Universal Extension Arms.....	58
Universal Bender.....	354
Universal Wheel Dresser.....	316

V

V-Angle Plates.....	82
---------------------	----

V-Blocks

Aluminum Cast.....	80
Magnetic.....	80
Cast Iron.....	80
Elongated.....	79
Four-Way.....	79
Granite.....	80
Multi-Use.....	78
Stainless Steel & Steel.....	78-79
Toolmaker's.....	78
Triple "V".....	79
V-Blocks & Clamps.....	78
Vee Blocks.....	79
Ultra Precision.....	78

V-Flange Tooling

Collet Chucks.....	222-223
Drill Chuck Arbors.....	243
Drill Chuck.....	221-222
End Mill Holders.....	221
ER Holder.....	223
Morse Taper.....	222
Retention Knobs.....	217-220
Shell Mill.....	222
Tool Setting Fixture.....	221

Valves, Coolant.....	337
Vernier Calipers.....	11-13
Vernier Height Gage.....	67

Vises

2-Way Swivel.....	265
Angle.....	259, 265, 343
Angle Tight.....	264
Centering.....	266
Cross Slide.....	218
Double Lock Type.....	263-265
Drill Press.....	259-260
EDM.....	327-328, 330
Machine (Horiz./Vert.).....	265
Machinist's.....	265
Milling.....	263-265
Pin.....	242
Quick Clamp Mill.....	260, 265
Rotary Table.....	268, 273
Screwless.....	325, 328
Screw Type.....	328-329
Self Centering CNC.....	224
Sine.....	326, 328
Stainless Steel.....	327-330

Super Lock.....	264
Swivel.....	326
Tilt.....	259, 326
Toolmaker's.....	325-329
Twin-Lock CNC.....	265
Universal Mount.....	326
Welder's.....	343

Vise Accessories

Adjustable Tailstock.....	269, 273
Dividing Plates.....	269, 273
Handles.....	263
Jaw Block.....	263
Jaws.....	261-262, 263
Mill Stop.....	262
Speed Handle.....	263
Swivel Bases.....	263
Work Stop.....	262
Worm Gear & Metal.....	273
VisiDresser.....	316

W

Wavy Parallels.....	77
Wedge Sets for Chucks.....	247
Wheel Dressers.....	316
Wheels, CBN.....	320
Wheels, Diamond.....	320
Wiggler/Center Finder.....	204
Wipes, Spindle.....	230
Wire Gage Drill Sets.....	87
Wire Measuring Gages.....	16, 30
Welder's Pliers.....	343
Work Lights & Magnifiers.....	331-333

Wrenches

5C Collet.....	279
Adjustable Face Spanner.....	351
Air.....	340
Combination.....	350
Coolant Hose.....	337
Drawbar.....	203
Drill Chuck.....	240
ER Collet.....	231-232
Hammer / Wrench Combo.....	201
Hex.....	165
Impact.....	340
Lathe Chuck.....	294
Tap & Reamer.....	102
Torque.....	350
Torx.....	165

X

XYZ Table Feeds.....	202
----------------------	-----

Z

Z-Axis Setters.....	215-216
Zero-Set Lathe Chucks/Backplates.....	292



▶ **PRECISION MEASURING TOOLS**

▶ **CARBIDE INSERTS**

▶ **CUTTING TOOLS**

▶ **MACHINE TOOL ACCESSORIES**

▶ **MRO & SHOP SUPPLIES**

▶ **AIR, POWER & HAND TOOLS**
